

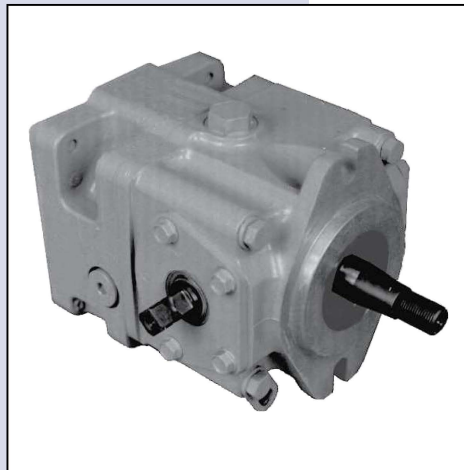

Series 40  
Direct  
Displacement  
Pumps

Technical  
Information





# Series 40 Direct Displacement Pumps

## Technical Information

### Revisions

#### History of Revisions

*Table of Revisions*

| Date           | Page  | Changed  | Rev. |
|----------------|-------|--|------|
| September 2013 | 5, 11 | change system pressure specs                             | FB   |
| August 2013    | all   | Remove M46 from manual                                   | FA   |
| February 2010  | last  | Fix Osaka address  | EI   |
| June 2009      | 56    | remove M25U outline drawing                              | EH   |
| July 2008      | 62    | add plug for Charge pressure construction port           | EG   |
| October 2007   | 31    | identified A Pad and B Pad as M35 and M44                | EF   |
| July 2007      | 22    | corrections to table - G factors for sample applications | ED   |
| June 2006      | 11    | corrections to maximum flow                              | EC   |
| May 2006       | 21    | Added an illustration to page 21                         | EB   |

© 2021 QCC LLC. All rights reserved.

QCC LLC accepts no responsibility for possible errors in catalogs, brochures and other printed material. QCC LLC reserves the right to alter its products without prior notice. This also applies to products already ordered, provided that such alterations can be made without affecting agreed specifications. All trademarks in this material are properties of their respective owners.



# Series 40 Direct Displacement Pumps

## Technical Information

### Contents

|                                 |  |    |
|---------------------------------|--|----|
| <b>Specifications</b>           | Design Specifications.....                   | 5  |
|                                 | Technical Specifications.....                | 5  |
|                                 | Operating Parameters.....                    | 5  |
|                                 | Options.....                                 | 6  |
|                                 | Fluid Specifications.....                    | 6  |
| <b>General Information</b>      | Series 40 Family of Pumps and Motors.....    | 7  |
|                                 | M25 Variable Pump.....                       | 8  |
|                                 | M35 Variable Pump (M44 is similar).....      | 8  |
|                                 | M35/44 Pump Schematic.....                   | 8  |
| <b>Features and Options</b>     | Key Features.....                            | 9  |
|                                 | Options.....                                 | 9  |
| <b>Operating Parameters</b>     | Fluids.....                                  | 10 |
|                                 | Viscosity.....                               | 10 |
|                                 | Temperature.....                             | 10 |
|                                 | Charge Pressure.....                         | 10 |
|                                 | Case Pressure.....                           | 10 |
|                                 | Pressure Ratings.....                        | 11 |
|                                 | Speed Ratings.....                           | 11 |
|                                 | Inlet Pressure.....                          | 12 |
|                                 | Theoretical Output.....                      | 12 |
| <b>System Design Parameters</b> | Sizing Equations.....                        | 13 |
|                                 | Filtration.....                              | 14 |
|                                 | Suction filtration.....                      | 14 |
|                                 | Charge filtration.....                       | 15 |
|                                 | Redundant Braking System Requirement.....    | 16 |
|                                 | Loop Flushing.....                           | 16 |
|                                 | Reservoir.....                               | 16 |
|                                 | Case Drain usage for Tandem Pumps.....       | 16 |
|                                 | Bearing Life and External Shaft Loading..... | 17 |
|                                 | Hydraulic Unit Life.....                     | 18 |
|                                 | Mounting Flange Loads.....                   | 19 |
| <b>Product Coding</b>           | Model Code.....                              | 20 |



# Series 40 Direct Displacement Pumps

## Technical Information

### Contents

#### Options

|   |    |
|---|----|
| Charge Pump .....                                   | 22 |
| Charge Pump Output Flow .....                       | 23 |
| Charge Pump Power Requirements .....                | 23 |
| Charge Relief Valve .....                           | 24 |
| Charge Check/High Pressure Relief Valve (HPRV)..... | 25 |
| Auxiliary Mounting Pads and Auxiliary Pumps .....   | 26 |
| Shaft Options .....                                 | 27 |

#### Installation Drawings

|  |    |
|--|----|
| M25 Variable Pump.....                     | 28 |
| M25 Tandem Pump.....                       | 29 |
| M35/44 Variable Pump .....                 | 30 |
| M35/44 Tandem Pump .....                   | 31 |
| Direct Displacement Control (DDC).....     | 32 |
| External control handle requirements ..... | 32 |
| M25 Variable Pump.....                     | 33 |
| M25 Tandem Pump.....                       | 35 |
| M35/44 Variable Pump .....                 | 37 |
| M35/44 Tandem Pump .....                   | 39 |

#### Performance Data

|                  |    |
|------------------|----|
| Performance..... | 41 |
|------------------|----|

#### Schematics

|                              |    |
|------------------------------|----|
| Single Pump Schematics ..... | 42 |
| Tandem Pump Schematics ..... | 43 |



# Series 40 Direct Displacement Pumps

## Technical Information

### Specifications

#### Design Specifications

|                                  |   |
|----------------------------------|---|
| <b>Product line</b>              | Series 40 Pumps   |
| <b>Pump type</b>                 | In-line, axial piston, variable, positive displacement pumps      |
| <b>Direction rotation</b>        | Clockwise (CW) or counterclockwise (CCW) available                |
| <b>Installation position</b>     | Discretionary, the housing must be filled with hydraulic fluid    |
| <b>Filtration configuration</b>  | Suction or charge pressure filtration                             |
| <b>Other system requirements</b> | Independent braking system, suitable reservoir and heat exchanger |

#### Technical Specifications

| Model                         | Unit   | M25 PV               | M35 PV             | M44 PV             | M25 PT                 | M35 PT                 | M44 PT                 |
|-------------------------------|--|----------------------|--------------------|--------------------|------------------------|------------------------|------------------------|
| <b>Pump configuration</b>     |  | Single variable pump |                    |                    | Tandem variable pump   |                        |                        |
| <b>Displacement</b>           | cm <sup>3</sup> /rev<br>[in <sup>3</sup> /rev] | 24.6<br>[1.50]       | 35.0<br>[2.14]     | 43.5<br>[2.65]     | 24.6 x 2<br>[1.50 x 2] | 35.0 x 2<br>[2.14 x 2] | 43.5 x 2<br>[2.65 x 2] |
| <b>Weight</b>                 | kg [lb]  | 19 [41.5]            | 25 [55]            | 25 [55]            | 24 [56]                | 45 [99]                | 45 [99]                |
| <b>Mass moment of inertia</b> | kg·m <sup>2</sup><br>[slug·ft <sup>2</sup> ]   | 0.0018<br>[0.0014]   | 0.0033<br>[0.0024] | 0.0032<br>[0.0023] | 0.0037<br>[0.0028]     | 0.0066<br>[0.0048]     | 0.0064<br>[0.0047]     |

#### Operating Parameters

| Model   | Unit                           | M25 PV        | M35 PV        | M44 PV        | M25 PT        | M35 PT        | M44 PT        |
|---|--------------------------------|---------------|---------------|---------------|---------------|---------------|---------------|
| <b>Case pressure</b>                                  |                                |               |               |               |               |               |               |
| <b>Continuous</b>                                     | bar [psi]                      | 1.7 [25]      |               |               |               |               |               |
| <b>Maximum</b>  | bar [psi]                      | 5.2 [75]      |               |               |               |               |               |
| <b>Speed limits</b>                                   |                                |               |               |               |               |               |               |
| <b>Rated @ max angle</b>                              | min <sup>-1</sup> (rpm)        | 4000          | 3600          | 3300          | 4000          | 3600          | 3300          |
| <b>Maximum @ max angle</b>                            | min <sup>-1</sup> (rpm)        | 5000          | 4500          | 4100          | 5000          | 4500          | 4100          |
| <b>Minimum</b>  | min <sup>-1</sup> (rpm)        | 500           | 500           | 500           | 500           | 500           | 500           |
| <b>System pressure</b>                                |                                |               |               |               |               |               |               |
| <b>Maximum Working</b>                                | bar [psi]                      | 345<br>[5000] | 380<br>[5511] | 345<br>[5000] | 345<br>[5000] | 380<br>[5511] | 345<br>[5000] |
| <b>Maximum</b>  | bar [psi]                      | 385<br>[5584] | 415<br>[6019] | 415<br>[6019] | 385<br>[5584] | 415<br>[6019] | 415<br>[6019] |
| <b>Theoretical max flow at rated speed (per pump)</b> | l/min<br>[US gal/min]          | 100<br>[26.0] | 126<br>[33.4] | 145<br>[38.3] | 100<br>[26.0] | 126<br>[33.4] | 145<br>[38.3] |
| <b>Inlet pressure</b>                                 |                                |               |               |               |               |               |               |
| <b>Continuous</b>                                     | bar absolute<br>[in Hg vacuum] | 0.8 [6.3]     |               |               |               |               |               |
| <b>Maximum</b>  | bar absolute<br>[in Hg vacuum] | 0.7 [9.2]     |               |               |               |               |               |



# Series 40 Direct Displacement Pumps

## Technical Information

### Specifications

#### Options

| Model                       | Unit  | M25 PV  | M35 PV         | M44 PV         | M25 PT     | M35 PT         | M44 PT         |
|-----------------------------|---|---|----------------|----------------|------------|----------------|----------------|
| Type of mounting            |   | SAE B   | SAE B          | SAE B          | SAE B      | SAE B          | SAE B          |
| Port connections            |   | Twin  | Twin           | Twin           | Twin       | Twin           | Twin           |
| Integral charge pump (std)  | cm <sup>3</sup> /rev [in <sup>3</sup> /rev] | -   | 11.8 [0.72]    | 11.8 [0.72]    | -          | 16.4 [1.00]    | 16.4 [1.00]    |
| Charge relief valve setting | bar [psi]                                   | 14.0 [200]  | 14.0 [200]     | 14.0 [200]     | 14.0 [200] | 14.0 [200]     | 14.0 [200]     |
| System pressure regulation  | bar [psi]                                   | 140-345 [2030-5000]                                     |                |                |            |                |                |
| Displacement limiters       |   | -   | -              | -              | -          | -              | -              |
| Input shaft option          |   | Splined, Tapered, or Straight Key                       |                |                |            |                |                |
| Auxiliary mounting pad      |   | SAE A   | SAE A<br>SAE B | SAE A<br>SAE B | SAE A      | SAE A<br>SAE B | SAE A<br>SAE B |
| Control options             |   | DDC   | DDC            | DDC            | DDC        | DDC            | DDC            |
| Filtration configuration    |   | Suction Filtration or Remote Charge Pressure Filtration |                |                |            |                |                |

#### Fluid Specifications

Ratings and data are based on operation with premium petroleum-based hydraulic fluids containing oxidation, rust, and foam inhibitors.

| Parameter             | Unit                             | Minimum                                      | Continuous     | Maximum     |
|-----------------------|----------------------------------|--|----------------|-------------|
| Viscosity             | mm <sup>2</sup> /sec (cSt) [SUS] | 7 [47]                                       | 12-60 [70-278] | 1600 [7500] |
| Temperature           | °C [°F]                          | -40 [-40]                                    | 82 [180]       | 104 [220]   |
| Cleanliness           |                                  | ISO 4406 Class 18/13 or better               |                |             |
| Filtration efficiency | suction filtration               | $\beta_{35-40}=75$ ( $\beta_{10} \geq 1.5$ ) |                |             |
|                       | charge filtration                | $\beta_{15-20}=75$ ( $\beta_{10} \geq 10$ )  |                |             |



## Series 40 Family of Pumps and Motors

# Series 40 Direct Displacement Pumps

## Technical Information

### General Information

Series 40 is a family of hydrostatic pumps and motors for medium power applications with maximum loads of 345 bar [5000 psi]. These pumps and motors can be applied together or combined with other products in a system to transfer and control hydraulic power.

Series 40 pump + motor transmissions provide an infinitely variable speed range between zero and maximum in both forward and reverse modes of operation. The pumps and motors each come in four frame sizes: M25, M35, M44, and M46.

Series 40 pumps are compact, high power density units. All models use the parallel axial piston / slipper concept in conjunction with a tiltable swashplate to vary the pump's displacement. Reversing the angle of the swashplate reverses the flow of fluid from the pump, reversing the direction of rotation of the motor output.

Series 40 - M35 and M44 pumps may include an integral charge pump to provide system replenishing and cooling fluid flow. M25 pumps are designed to receive charge flow from an auxiliary circuit or from a gear pump mounted on the auxiliary mounting pad. Series 40 pumps feature a range of auxiliary mounting pads to accept auxiliary hydraulic pumps for use in complementary hydraulic systems.

For complete technical information on M46 pumps, refer to *M46 Pumps Technical Information, L1001029*.

Series 40 motors use the parallel axial piston/slipper design in conjunction with a fixed or tiltable swashplate. The family includes M25, M35, M44 fixed motor units and M35, M44, M46 variable motor units. For complete technical information on Series 40 motors, refer to *Series 40 Motors Technical Information, 520L0636*.

The M35 and M44 variable motors feature a trunnion style swashplate and direct displacement control. The M46 variable motors use a cradle swashplate design and a two-position hydraulic servo control.

The M46 variable motor is available in a cartridge flange version, which is designed to be compatible with CW and CT compact planetary gearboxes. This combination provides a short final drive length for applications with space limitations.

#### M25 Variable Pump

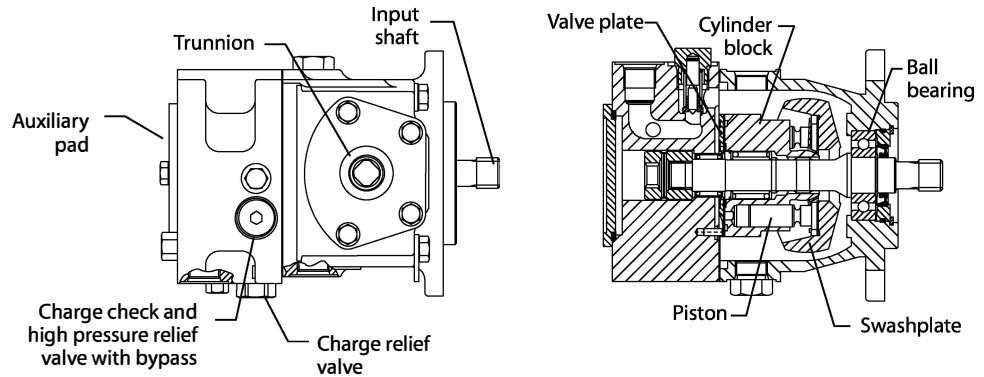

P100 583E

#### M35 Variable Pump (M44 is similar)

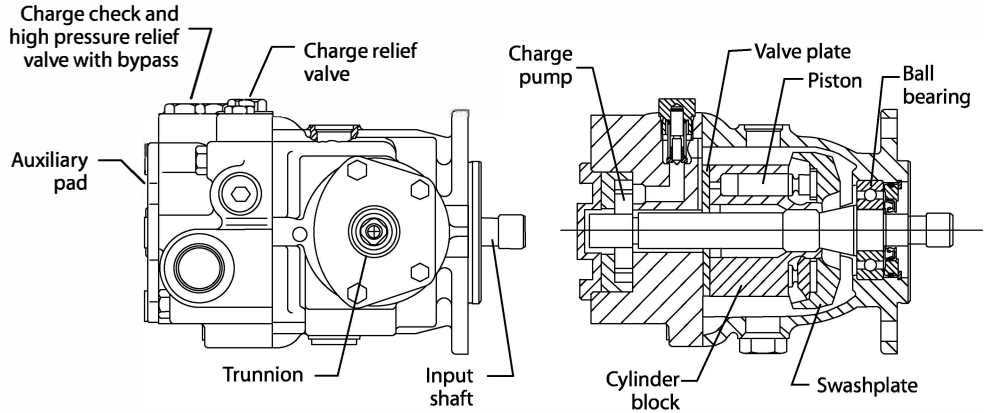

P100 584E

A variable pump is shown in a hydraulic circuit with a fixed motor. The pump shown features manual displacement control. The circuit features suction filtration and heat exchanger.

#### M35/44 Pump Schematic

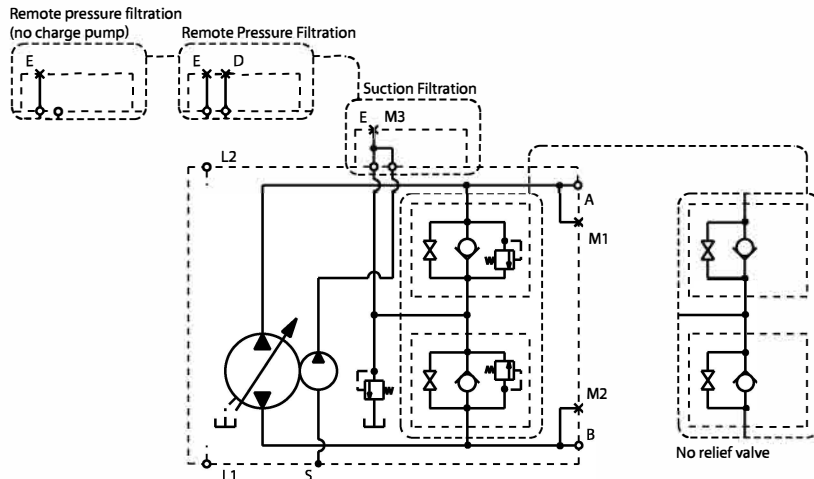

P100 638E





## Series 40 Direct Displacement Pumps

### Technical Information

### Features and Options

#### Key Features

- 3 sizes of variable displacement pumps
- 3 sizes of tandem pumps
- 3 sizes of variable displacement motors
- 3 sizes of fixed displacement motors
- Efficient axial piston design
- Proven reliability and performance
- Compact, lightweight
- Worldwide sales and service

#### Options

**High Pressure Relief Valve (HPRV)** - A high pressure relief valve limits the system pressure to protect the system from over-pressure.

**Charge Relief Valve** - The charge pressure relief valve regulates charge pressure.

**Displacement Limiters** - Optional displacement limiters allow maximum displacement adjustment to allow for fine tuning of the propel system.

**Auxiliary Mounting Pads** - Several auxiliary mounting pad options allow for adding a second pump.

**Input Shafts** - Straight keyed, tapered keyed, and several splined shaft options are available.



# Series 40 Direct Displacement Pumps

## Technical Information

### Operating Parameters

#### Fluids

Ratings and performance data are based on operating with premium hydraulic fluids containing oxidation, rust, and foam inhibitors. These include premium turbine oils, API CD engine oils per SAE J183, M2C33F or G automatic transmission fluids (ATF), Dexron II (ATF) meeting Allison C-3 or Caterpillar T0-2 requirements, and certain specialty agricultural tractor fluids. For more information on hydraulic fluid selection, see QCC LLC publications: *Hydraulic Fluids and Lubricants, Technical Information, 520L0463* and, *Experience with Biodegradable Hydraulic Fluids, Technical Information, 520L465*.

#### Viscosity

Maintain fluid viscosity within the recommended range for maximum efficiency and bearing life. **Minimum viscosity** is acceptable only during brief occasions of maximum ambient temperature and severe duty cycle. **Maximum viscosity** is acceptable only at cold start: Limit speeds until the system warms up. See QCC LLC publications: *Hydraulic Fluids and Lubricants, Technical Information, 520L0463*

#### Fluid viscosity limits

| Condition  | mm <sup>2</sup> /s (cSt) | SUS    |
|------------|--------------------------|--------|
| Minimum    | 7                        | 47     |
| Continuous | 12-60                    | 70-278 |
| Maximum    | 1600                     | 7500   |

#### Temperature

Maintain fluid temperature within the limits shown in the table. **Minimum temperature** relates to the physical properties of the component materials. Cold oil will not affect the durability of the motor components. However, it may affect the ability of the motor to transmit power. **Maximum temperature** is based on material properties: Don't exceed it. Measure maximum temperature at the hottest point in the system. This is usually the case drain.

#### Temperature limits

|   |                   |
|---|-------------------|
| <b>Minimum (intermittent, cold start)</b> | - 40° C [- 40° F] |
| <b>Continuous</b>                         | 82.2° C [180° F]  |
| <b>Maximum</b>                            | 104.4° C [220° F] |

---

Ensure fluid temperature and viscosity limits are concurrently satisfied.

---

#### Charge Pressure

All systems require a charge (positive pressure) in the low side of the system loop for proper lubrication and rotating group operation. Maintain low loop (charge) pressure at a minimum of 6 bar [87 psi] above case pressure.

#### Case Pressure

Maintain case pressure within the limits shown in the table. Ensure housing is filled with hydraulic fluid.

#### Case pressure limits

|                                  |                  |
|----------------------------------|------------------|
| <b>Maximum (continuous)</b>      | 1.7 bar [25 psi] |
| <b>Intermittent (cold start)</b> | 5.2 bar [75 psi] |

#### ⚠ Caution

Operating outside of charge and case pressure limits will damage the pump. To minimize this risk, use full size inlet and case drain plumbing, and limit line lengths.

---



## Series 40 Direct Displacement Pumps

### Technical Information

### Operating Parameters

#### Pressure Ratings

**System pressure** is the differential pressure between high pressure system ports. It is the dominant operating variable affecting hydraulic unit life. High system pressure, which results from high load, reduces expected life. Hydraulic unit life depends on the speed and normal operating, or weighted average, pressure that can only be determined from a duty cycle analysis.

**Application pressure** is the high pressure relief or pressure limiter setting normally defined within the order code of the pump. This is the applied system pressure at which the driveline generates the maximum calculated pull or torque in the application.

**Maximum Working pressure** is the highest recommended application pressure. Maximum working pressure is not intended to be a continuous pressure. Propel systems with application pressures at, or below, this pressure should yield satisfactory unit life given proper component sizing.

**Maximum pressure** is the highest allowable application pressure under any circumstance. Application pressures above maximum working pressure will only be considered with duty cycle analysis and factory approval.

**Minimum low loop pressure** must be maintained under all operating conditions to avoid cavitation.

---

All pressure limits are differential pressures referenced to low loop (charge) pressure. Subtract low loop pressure from gauge readings to compute the differential.

---

#### Speed Ratings

The table, *Operating Parameters* in the *Specifications* section, gives rated and maximum speeds for each displacement. Not all displacements operate under the same speed limits. Definitions of these speed limits appear below.

**Continuous speed** is the maximum recommended operating speed at full power condition. Operating at or below this speed should yield satisfactory product life. Do not exceed maximum motor speed during unloaded, on-road travel over level ground.

**Maximum speed** is the highest operating speed permitted. Exceeding maximum speed reduces pump life and can cause loss of hydrostatic power and braking capacity. Never exceed the maximum speed limit under any operating conditions.

#### Warning

##### **Unintended vehicle or machine movement hazard.**

The loss of hydrostatic drive line power, in any mode of operation (forward, neutral, or reverse) may cause the system to lose hydrostatic braking capacity. You must provide a braking system, redundant to the hydrostatic transmission, sufficient to stop and hold the vehicle or machine in the event of hydrostatic drive power loss.

---



# Series 40 Direct Displacement Pumps

## Technical Information

### Operating Parameters

#### Inlet Pressure

Achieving acceptable pump life and performance requires proper charge pump inlet design. A **continuous inlet pressure** of not less than 0.8 bar abs. (not more than 6.3 in. Hg vac.) is recommended. Normal pressure less than the **minimum inlet pressure** of 0.7 bar abs. (greater than 9.2 in. Hg vac.) indicates inadequate inlet design or a restricted filter. Pressures less than 0.7 bar abs. (greater than 9.2 in. Hg vac.) during cold start are possible, but should improve quickly as the fluid warms.

#### *Inlet pressure*

|                   | bar absolute | in. Hg vacuum |
|-------------------|--------------|---------------|
| <b>Continuous</b> | 0.8          | 6             |
| <b>Minimum</b>    | 0.7          | 9.2 (max)     |

#### Theoretical Output

The theoretical maximum flow at rated speed is a simple function of pump displacement and speed. This is a good gauge for sizing a companion motor. This does not take into account losses due to leakage or variations in displacement.



## Series 40 Direct Displacement Pumps Technical Information System Design Parameters

### Sizing Equations

Use these equations to help choose the right pump size and displacement for your application.

#### Based on SI units

*Flow* Output flow  $Q = \frac{V_s \cdot n \cdot \eta_v}{1000}$  (l/min)

*Torque* Input torque  $M = \frac{V_s \cdot \Delta p}{20 \cdot \pi \cdot \eta_m}$  (N·m)

*Power* Input power  $P = \frac{M \cdot n \cdot \pi}{30\,000} = \frac{Q \cdot \Delta p}{600 \cdot \eta_t}$  (kW)

#### Based on US units

Output flow  $Q = \frac{V_s \cdot n \cdot \eta_v}{231}$  (US gal/min)

Input torque  $M = \frac{V_s \cdot \Delta p}{2 \cdot \pi \cdot \eta_m}$  (lbf·in)

Input power  $P = \frac{M \cdot n \cdot \pi}{198\,000} = \frac{Q \cdot \Delta p}{1714 \cdot \eta_t}$  (hp)

#### Variables SI units [US units]

|            |  |   |
|------------|--|---|
| $V_s$      | = Displacement per revolution                  | cm <sup>3</sup> /rev [in <sup>3</sup> /rev] |
| $p_o$      | = Outlet pressure                              | bar [psi]                                   |
| $p_i$      | = Inlet pressure                               | bar [psi]                                   |
| $\Delta p$ | = $p_o - p_i$ (system pressure)                | bar [psi]                                   |
| $n$        | = Speed  | min <sup>-1</sup> (rpm)                     |
| $\eta_v$   | = Volumetric efficiency                        |   |
| $\eta_m$   | = Mechanical efficiency                        |   |
| $\eta_t$   | = Overall efficiency ( $\eta_v \cdot \eta_m$ ) |   |

## Series 40 Direct Displacement Pumps Technical Information System Design Parameters

### Filtration

Ensure fluid entering pump is free of contaminants to prevent damage (including premature wear) to the system. Series 40 pumps require system filtration capable of maintaining fluid cleanliness at ISO 4406-1999 class 22/18/13 or better.

Consider these factors when selecting a system filter:

- Cleanliness specifications
- Contaminant ingress rates
- Flow capacity
- Desired maintenance interval

Locate filter either on the inlet (suction filtration) or discharge (charge pressure filtration) side of the charge pump. Series 40 pumps are available with provisions for either strategy.

Typically, a filter with a beta ratio of  $\beta_{10} = 1.5$  to 2.0 is adequate. However, open circuit systems supplied from a common reservoir may have considerably higher requirements. Because each system is unique, only a thorough testing and evaluation program can fully validate the filtration system. For more information, see QCC LLC publication *Design Guidelines for Hydraulic Fluid Cleanliness*, **520L0467**.

#### Suction filtration

The suction filter is placed in the circuit between the reservoir and the inlet to the charge pump as shown in the accompanying illustration.

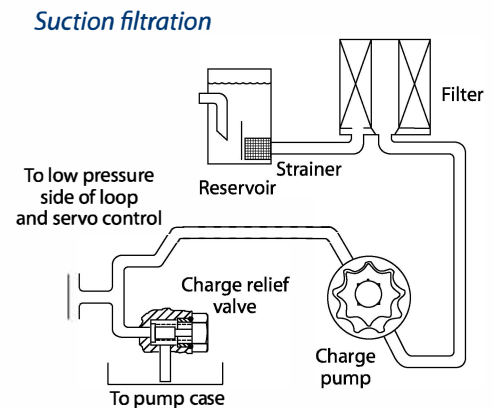

P100 588E

### Filtration (continued)

#### Charge filtration

Provision for charge pressure filtration is available on all Series 40 pumps. The pressure filter is remotely mounted in the circuit after the charge pump, as shown in the accompanying illustration.

Filters used in charge pressure filtration circuits must be rated to at least 34.5 bar [500 psi] pressure. A 100 - 125  $\mu\text{m}$  screen located in the reservoir or in the charge inlet line is recommended when using charge pressure filtration.

A filter bypass valve is necessary to prevent filter damage and to avoid contaminants from being forced through the filter media by high pressure differentials across the filter. In the event of high pressure drop associated with a blocked filter or cold start-up conditions, fluid will bypass the filter. Avoid working with an open bypass for an extended period. We recommend a visual or electrical bypass indicator. Proper filter maintenance is mandatory.

#### Charge filtration

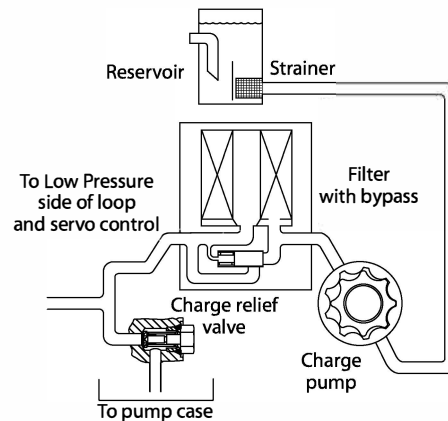

P106 102E



## Series 40 Direct Displacement Pumps Technical Information System Design Parameters

### Redundant Braking System Requirement

#### **▲ Warning**

##### **Unintended vehicle or machine movement hazard.**

The loss of hydrostatic drive line power, in any mode of operation (forward, neutral, or reverse) may cause the system to lose hydrostatic braking capacity. You must provide a braking system, redundant to the hydrostatic transmission, sufficient to stop and hold the vehicle or machine in the event of hydrostatic drive power loss.

### Loop Flushing

Closed circuit systems may require loop flushing to meet temperature and cleanliness requirements. A loop flushing valve removes hot fluid from the low pressure side of the system loop for additional cooling and filtering. Ensure the charge pump provides adequate flow for loop flushing and the loop flushing valve does not cause charge pressure to drop below recommended limits.

### Reservoir

The reservoir provides clean fluid, dissipates heat, and removes entrained air from the hydraulic fluid. It allows for fluid volume changes associated with fluid expansion and cylinder differential volumes. Minimum reservoir capacity depends on the volume needed to perform these functions. Typically, a capacity of one half the charge pump flow (per minute) is satisfactory for a closed reservoir. Open circuit systems sharing a common reservoir require greater fluid capacity.

Locate the reservoir outlet (suction line) near the bottom, allowing clearance for settling foreign particles. Use a 100 - 125  $\mu\text{m}$  screen covering the outlet port.

Place the reservoir inlet (return lines) below the lowest expected fluid level, as far away from the outlet as possible.

Use a baffle (or baffles) between the reservoir inlet and outlet ports to promote de-aeration and reduce fluid surging.

### Case Drain usage for Tandem Pumps

On tandem pumps, excess flow from the charge relief valve is routed into the housing of the front pump. In order to ensure adequate case flushing, it is recommended that the rear housing drain ports be used as the case drain.

---

M43/M44 tandem pumps with the option of opposing port endcaps do not follow the above rule.

---





## Series 40 Direct Displacement Pumps Technical Information System Design Parameters

### Bearing Life and External Shaft Loading

**Bearing life** is a function of speed, pressure and swashplate angle plus any external loads. Other life factors include oil type and viscosity.

In vehicle propulsion drives with no external loads, where the speed, pressure, and swashplate angle are often changing, normal bearing B10 (90% survival) life will exceed the hydraulic unit life.

In non-propel drives, such as conveyors or fan drives, the operating speed and pressure may be nearly constant leading to a distinctive duty cycle compared to that of a propulsion drive. In these types of applications, a bearing life review is recommended.

Series 40 pumps are designed with bearings that can accept some incidental external radial and thrust loads. However, any amount of external load will reduce the expected bearing life.

The allowable radial shaft loads are a function of the load position, the load orientation, and the operating pressures of the hydraulic unit. All external shaft loads have an effect on bearing life. In applications where external shaft loads cannot be avoided, the impact on bearing life can be minimized by orienting the load to the 90 or 270 degree position.

The **maximum allowable radial loads** ( $R_e$ ), based on the **maximum external moment** ( $M_e$ ) and the distance ( $L$ ) from the mounting flange to the load, may be determined from the tables below and drawings on the next page .

The maximum allowable radial load is calculated as:  $R_e = M_e / L$

Avoid thrust loads in either direction.

If continuously applied external radial loads are 25% or more of the maximum allowable, or thrust loads are known to occur, contact your QCC LLC representative for an evaluation of unit bearing life. Optional high capacity bearings are available.

Tapered output shafts or *clamp-type* couplings are recommended for applications where radial shaft side loads are present.

#### Shaft loading parameters

|       |  |
|-------|--|
| $R_e$ | Maximum radial load                            |
| $M_e$ | Maximum external moment                        |
| $L$   | Distance from mounting flange to point of load |
| $F_e$ | Force of cylinder block                        |
| $T_e$ | Thrust load                                    |

#### Maximum external shaft moments

|                         | M25       | M35/44     |
|-------------------------|-----------|------------|
| $M_e/N\cdot m$ [in·lbf] | 101 [890] | 121 [1075] |

**Bearing Life and External Shaft Loading (continued)**

*180° External radial shaft load*

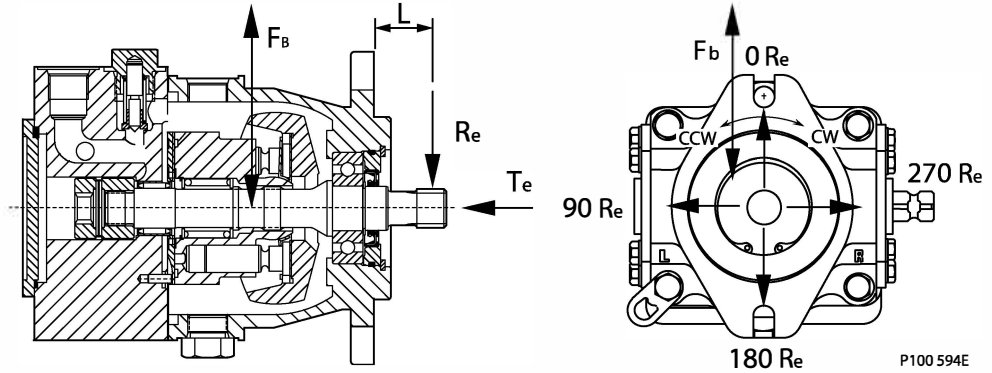

*Direction of external shaft load*

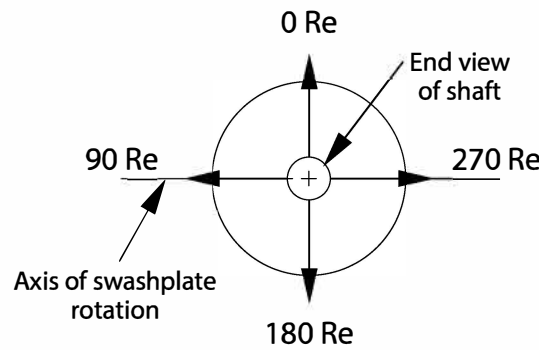

**Hydraulic Unit Life**

**Hydraulic unit life** is defined as the life expectancy of the hydraulic components. It is a function of speed and system pressure; however, system pressure is the dominant operating variable. High pressure, which results from high load, reduces expected life.

Design the hydraulic system to a projected machine duty cycle. Know the expected percentages of time at various loads and speeds. Ask your QCC LLC representative to calculate an appropriate pressure based your hydraulic system design. If duty cycle data is not available, input power and pump displacement are used to calculate system pressure.

All pressure limits are differential pressures (referenced to charge pressure) and assume normal charge pressure.

Series 40 pumps will meet satisfactory life expectancy if applied within the parameters specified in this bulletin. For more detailed information on hydraulic unit life see *Pressure and Speed Limits, BLN-9884*.

#### Mounting Flange Loads

**Shock load moment** is the result of an instantaneous jolt to the system. **Continuous load moments** are generated by the typical vibratory movement of the application. Avoid excessive loading of the mounting flange such as adding tandem mounted auxiliary pumps and/or subjecting pumps to high shock loads. Design pump applications to stay within the allowable shock load moment and allowable continuous load moment.

Use the following formulas to estimate overhung load moment for multiple pump mountings:

$$M_s = G_s (W_1 L_1 + W_2 L_2 + \dots + W_n L_n)$$

$$M_c = G_c (W_1 L_1 + W_2 L_2 + \dots + W_n L_n)$$

Refer to the *Installation Drawings* section to find pump length (L). Refer to the table *Technical Specifications* in the *Specifications* section, to find pump weight (W). An exact measure of W will depend on the pump's features.

The tables below show allowable overhung load moment values. If system parameters exceed these values add additional pump support.

Estimated maximum and continuous acceleration factors for some typical Series 40 applications are shown. Applications which experience extreme resonant vibrations may require additional pump support. Typical continuous (vibratory) values can vary significantly due to changes in engine and pump configuration and mounting methods.

#### Overhung loading parameters

|                      |  |
|----------------------|--|
| <b>M<sub>s</sub></b> | Shock load moment  |
| <b>M<sub>c</sub></b> | Continuous load moment   |
| <b>G<sub>s</sub></b> | Maximum shock acceleration (Gs)                                |
| <b>G<sub>c</sub></b> | Continuous (vibratory) acceleration (Gs)                       |
| <b>W<sub>n</sub></b> | Weight of nth pump   |
| <b>L<sub>n</sub></b> | Distance from mounting flange to center of gravity of nth pump |

#### Allowable overhung parameters

| Frame size | Continuous load moment (M <sub>c</sub> ) |          | Shock load moment (M <sub>s</sub> ) |          |
|------------|--|----------|-------------------------------------|----------|
|            | N•m                                      | [in•lbf] | N•m                                 | [in•lbf] |
| M25 PV     | 361                                      | [3200]   | 617                                 | [5470]   |
| M25 PT     | 361                                      | [3200]   | 559                                 | [4950]   |
| M35 PV     | 517                                      | [4600]   | 832                                 | [7400]   |
| M35 PT     | 517                                      | [4600]   | 754                                 | [6700]   |

#### Shaft loading parameters

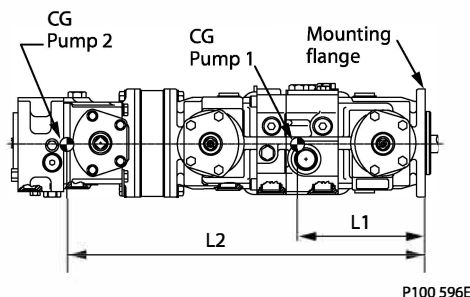

#### G-factors for sample applications

| Application             | Continuous (vibratory) acceleration (G <sub>c</sub> ) | Maximum (shock) acceleration (G <sub>s</sub> ) |
|-------------------------|---|--|
| Skid steer loader       | 4   | 10   |
| Trencher (rubber tires) | 3   | 8  |
| Asphalt paver           | 2   | 6  |
| Windrower               | 2   | 5  |
| Aerial lift             | 1.5   | 4  |
| Turf care vehicle       | 1.5   | 4  |
| Vibratory roller        | 6   | 10   |

\* Applications which experience extreme resonant vibrations require addition pump support.

### Model Code

### Series 40 variable pump

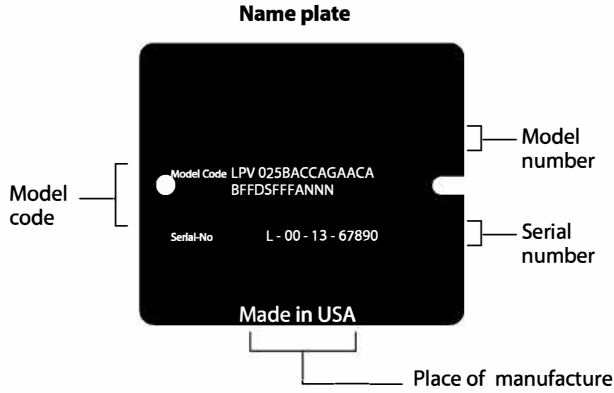

### Model code modules

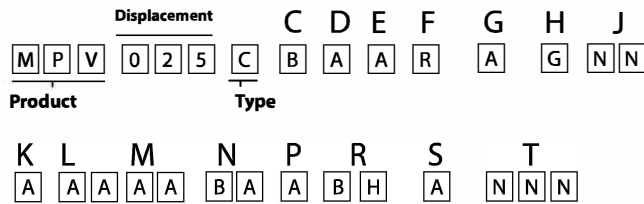

- C: Swashplate group
- D: Seal group
- E: Input shaft
- F: Rotation
- G: Charge pump displacement
- H: Charge pressure relief setting
- J: Filtration
- K: Displacement limiters
- L: Bypass valve
- M: System pressure protection
- N: Control
- P: Control handle position
- R: Control orifice diameters
- S: Auxiliary mounting pad
- T: Special hardware



# Series 40 Direct Displacement Pumps Technical Information Model Code

## Model Code (continued)

### Series 40 tandem pump

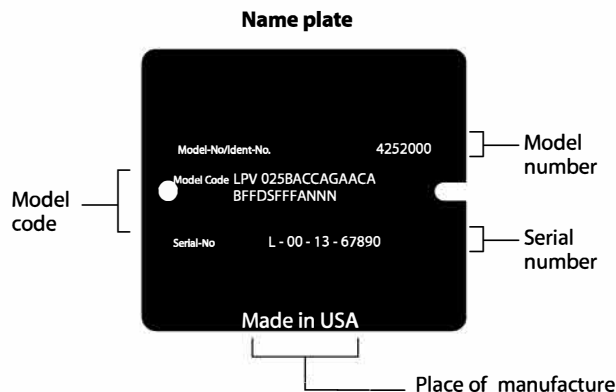

### Model code modules

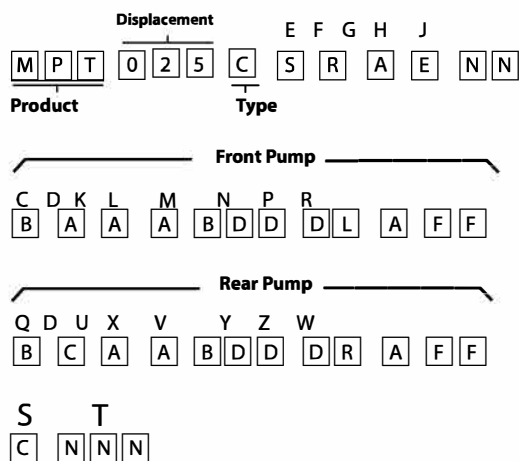

- E: Input shaft
- F: Rotation
- G: Charge pump displacement
- H: Charge pressure relief setting
- J: Filtration
- C & Q: Swashplate
- D: Seal group
- K & U: Displacement
- L & X: Bypass valve
- M & V: System pressure protection
- N & Y: Control
- P & Z: Control handle position
- R & W: Control orifice
- S: Auxiliary mounting flange
- T: Special hardware

## Series 40 Direct Displacement Pumps Technical Information Options

### Charge Pump

Charge flow is required on all Series 40 units applied in closed circuit installations to make up for internal leakage, maintain positive pressure in the main circuit, provide flow for cooling, replace any leakage losses from external valving or auxiliary systems, and on M46 units, to provide flow and pressure for the control system.

---

Maintain rated charge pressure under all conditions of operation to prevent damage to the transmission.

---

*Charge pump in series 40 - M35 PV*

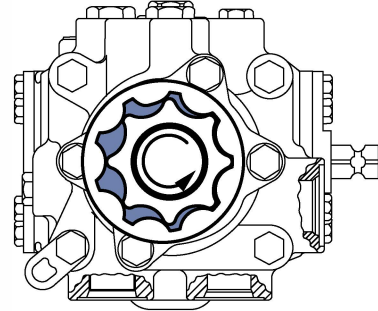

P100.589E

All Series 40 pumps (except M25 pumps) may be equipped with integral charge pumps. These charge pump sizes have been selected to meet the needs of a majority of Series 40 applications.

Many factors influence the charge flow requirements and the resulting charge pump size selection. These factors include system pressure, pump speed, pump swashplate angle, type of fluid, temperature, size of heat exchanger, length and size of hydraulic lines, control response characteristics, auxiliary flow requirements, hydraulic motor type, etc. In most Series 40 applications a general guideline is that the charge pump displacement should be equal to or greater than 10% of the total displacement of all units in the system.

The total charge flow requirement is the sum of the charge flow requirements of each of the components in the system. Use the information provided on the following pages to make a charge pump selection for a given application.



# Series 40 Direct Displacement Pumps

## Technical Information

### Options

#### Charge Pump (continued)

System features and conditions that may invalidate the 10% of displacement rule include (but are not limited to):

- Operation at low input speeds (below 1500 RPM)
- Shock loading
- Excessively long system lines
- Auxiliary flow requirements
- Use of low speed high torque motors

If a charge pump of sufficient displacement to meet the 10% of displacement rule is not available or if any of the above conditions exist which could invalidate the 10% rule, contact your QCC LLC representative. A charge pump sizing worksheet is available in [Selection of Driveline Components, BLN-9885](#).

M25 pumps do not allow for integral charge pumps. Other Series 40 pumps are also available without charge pumps. When an integral charge pump is not used, an external charge supply is required to ensure adequate charge pressure and cooling.

#### Charge Pump Output Flow

Flow at standard charge relief setting, 70°C [160°F] inlet

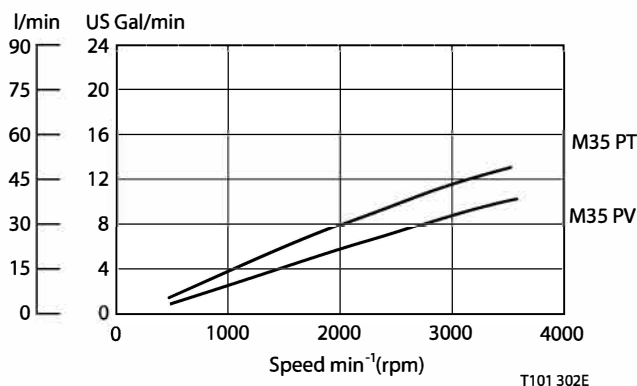

#### Charge Pump Power Requirements

Power at standard charge relief setting, 70°C [160°F] inlet

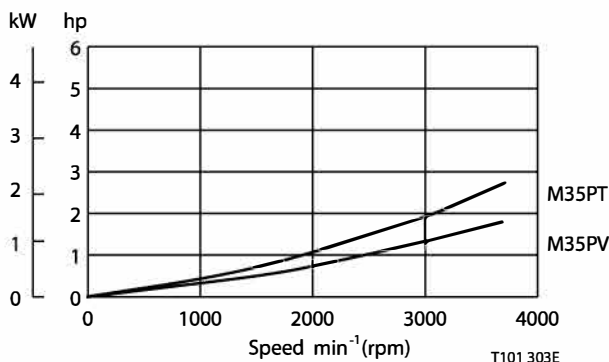



# Series 40 Direct Displacement Pumps

## Technical Information

### Options

#### Charge Relief Valve

An integral charge pressure relief valve provides a relief outlet for charge pressure. This valve, in effect, sets charge pressure. Flow through the valve is ported to case.

The charge relief valve for the M25, M35, and M44 PV/PT is a flat poppet style valve.

The nominal charge relief setting is referenced to case pressure. It is factory set at 1800 min<sup>-1</sup> (rpm) with the pump in neutral position. A proper charge relief setting takes into account input speeds and control requirements.

The charge pressure setting for pumps without an internal charge pump is set with an externally supplied charge flow of 19 l/min [5 US gal/min] on pumps and 38 l/min [10 US gal/min] on tandem pumps. These units must have adequate charge flow supplied to the charge inlet in order to maintain charge pressure at all times.

Incorrect charge pressure settings may result in the inability to build required system pressure and/or inadequate loop flushing flows. Ensure correct charge pressure under all conditions of operation to maintain pump control performance.

The charge relief valve is factory set. If necessary, it can be field adjusted with shims.

#### Charge relief valve specs

|  | M25 | M35                                  | M44 |
|--|-----|--------------------------------------|-----|
| <b>Type</b>  |     | Flat poppet valve                    |     |
| <b>Available setting</b>   |     | 7.5-14 bar [110-200 psi]             |     |
| <b>Adjustment</b>  |     | Via shims inside of valve cartridge* |     |
| *Shimming offers adjustment over a limited range, a spring change may be required to make a larger adjustment. |     |                                      |     |

#### Charge relief valve locations

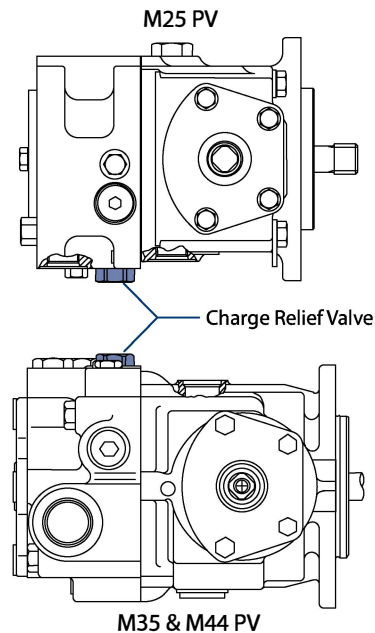

P100.591E





## Series 40 Direct Displacement Pumps Technical Information Options

### Charge Check/High Pressure Relief Valve (HPRV)

Charge check and high pressure relief valves maintain circuit pressure in the proper range. The check valves allow charge flow to replenish the low pressure side of the working loop. The high pressure relief valves provide pressure protection to the high pressure side of the working loop. There are two cartridge style valves to handle each side of the working loop with flow in either direction.

High pressure relief valves are available in a range of settings. You may specify individual port pressure settings. If high pressure relief valves are not desired, pumps may be equipped with charge circuit check valves only.

#### ⚠ Caution

High pressure relief valves are intended for transient overpressure protection and are not intended for continuous pressure control. Flow over relief valves for extended periods of time may result in severe heat build up. High flows over relief valves may result in pressure levels exceeding the nominal valve setting and potential damage to system components.

#### Check/high relief valve specs

|                |                              |
|----------------|------------------------------|
| <b>Type</b>    | Cartridge-style poppet valve |
| <b>Setting</b> | 140-345 bar (2030-5000 psi)  |
| <b>Option</b>  | Check only - no relief valve |

#### High pressure relief valve locations

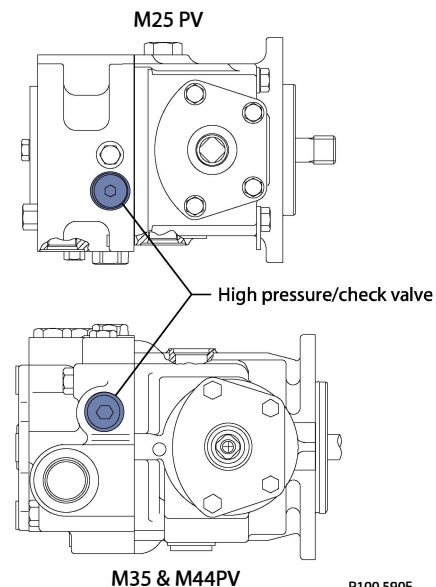

#### Auxiliary Mounting Pads and Auxiliary Pumps

Auxiliary mounting pads are available on all Series 40 pumps. A sealed cover is included as standard equipment on all mounting pads.

An O-ring seals the auxiliary pump mounting flange to the pad. The drive coupling is lubricated with oil from the main pump case.

Spline specifications and torque ratings are shown in the accompanying table.

- All auxiliary mounting pads meet SAE J744 specifications.
- Do not exceed the maximum pump input shaft rating.
- Applications subject to severe vibratory or high G loading require an additional structural support. This is necessary to prevent leaks and possible mounting flange damage. Refer to *Mounting Flange Loads* in the *System Design Parameters* section for additional information.

#### Auxiliary mounting pad specs

| Internal spline size | Pad size | Torque rating |     |            | Availability |     |     |
|----------------------|----------|---------------|-----|------------|--------------|-----|-----|
|                      |          |               | N·m | [in · lbf] | M25          | M35 | M44 |
| 9T<br>16/32P         | SAE A    | Continuous:   | 51  | [450]      | m            | m   | m   |
|                      |          | Max:          | 107 | [950]      |              |     |     |
| 11T<br>16/32P        | SAE A    | Continuous:   | 90  | [800]      | m            | m   | m   |
|                      |          | Max:          | 147 | [1300]     |              |     |     |
| 13T<br>16/32P        | SAE B    | Continuous:   | 124 | [1100]     | —            | m   | m   |
|                      |          | Max:          | 248 | [2200]     |              |     |     |

The drawing and table below show the dimensions of the auxiliary pump mounting flanges and shafts. Auxiliary pump mounting flanges and shafts with the dimensions noted are compatible with the auxiliary mounting pads on the Series 40 pumps.

#### Auxiliary pump mating dimensions mm [in.]

| Pad size | P                 | B               | C                | D              | E              | F              |
|----------|-------------------|-----------------|------------------|----------------|----------------|----------------|
| SAE A    | 82.55<br>[32.50]  | 6.35<br>[0.250] | 12.70<br>[0.500] | 58.2<br>[2.29] | 15.0<br>[0.59] | 13.5<br>[0.53] |
| SAE B    | 101.60<br>[4.000] | 9.65<br>[0.380] | 15.2<br>[0.60]   | 53.1<br>[2.09] | 17.5<br>[0.69] | 14.2<br>[0.56] |

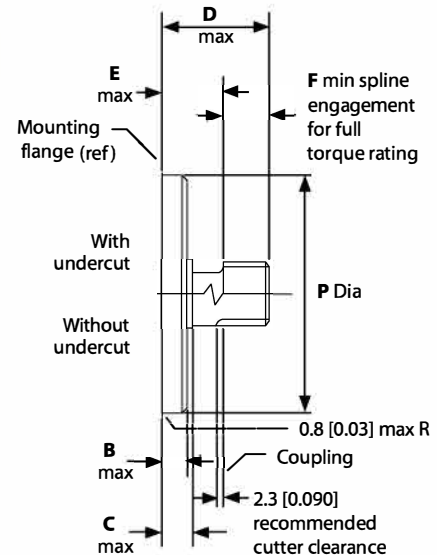

P100 636E

### Auxiliary Mounting Pads and Auxiliary Pumps (continued)

*Auxiliary mounting pads on Series 40 pumps*

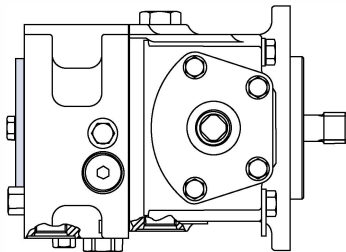

M25 PV

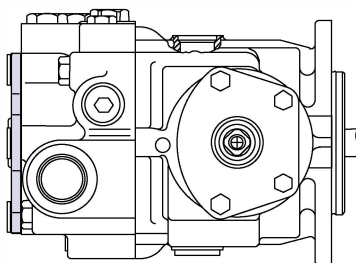

M35 & M44 PV

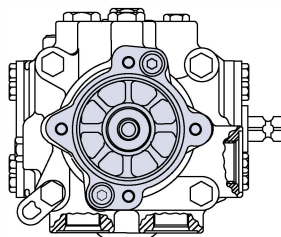

A Pad  
M35 & M44 PV

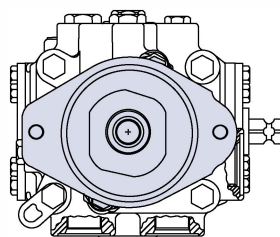

B Pad  
M35 & M44 PV

P100 593E

### Shaft Options

Series 40 pumps are available with a variety of splined, straight keyed, and tapered shaft ends. Nominal shaft sizes and torque ratings are shown in the table on the next page.

Torque ratings assume no external radial loading. **Continuous torque** ratings for splined shafts are based on splined tooth wear, and assume the mating spline has a minimum hardness of  $R_c 55$  and full spline depth with good lubrication.

**Maximum torque** ratings are based on shaft torsional strength and assume a maximum of 200,000 load reversals.

---

**Recommended mating splines for Series 40 splined output shafts should be in accordance with ANSIB92.1 Class 5.** QCC LLC external splines are modified Class 5 Fillet Root Side Fit. The external splined Major Diameter and Circular Tooth Thickness dimensions are reduced in order to assure a clearance fit with the mating spline. Other shaft options may exist. Contact your QCC LLC representative for availability.

---

**M25 Variable Pump**

| Code | Description  | Torque rating                         |  | Drawing          |
|------|--|---------------------------------------|--|------------------|
|      |  | Maximum torque rating<br>N•m [lbf•in] | Continuous torque rating<br>N•m [lbf•in] |                  |
| Y    | Ø 22.20 mm [0.874 in]<br>Straight keyed                | 140 [1240]                            | —  | <p>P104 403E</p> |
| A    | 13-tooth<br>16/32 pitch<br>(ANSI B92.1 1970 - Class 5) | 140 [1240]                            | 85 [750]                                 | <p>P104 404E</p> |
| C    | Ø 25.4 mm [1.000 in]<br>1:8 taper (SAE J501)           | 140 [1240]                            | —  | <p>P104 405E</p> |

**M25 Tandem Pump**

| Code | Description  | Torque rating                         |  | Drawing |
|------|--|---------------------------------------|--|---------|
|      |  | Maximum torque rating<br>N•m [lbf•in] | Continuous torque rating<br>N•m [lbf•in] |         |
| Y    | Ø 22.20 mm [0.874 in]<br>Straight keyed                | 140 [1240]                            | —  |         |
| A    | 13-tooth<br>16/32 pitch<br>(ANSI B92.1 1970 - Class 5) | 140 [1240]                            | 85 [750]                                 |         |
| C    | Ø 25.4 mm [1.000 in]<br>1:8 taper (SAE J501)           | 140 [1240]                            | —  |         |

#### Direct Displacement Control (DDC)

The Direct Displacement Control (DDC) can be located on either side of a Series 40 - M25, M35, or M44 pump. It provides a simple, positive method of control. Movement of the control shaft causes a proportional swashplate movement, thus varying the pump's displacement from full displacement in one direction to full displacement in the opposite direction.

Some applications (generally vehicle propel) require a provision for non-linear control input to reduce control sensitivity near neutral. Damping or frictional forces may be necessary to produce desirable control feel.

Neutral position is not factory set, nor is there any internal neutral return mechanism. The application must include provisions for all control linkage and neutral return functionality.

---

With no external forces applied to the swashplate trunnion, internal hydraulic forces may not return the swashplate to the neutral position under all conditions of operation.

---

The DDC is available on variable pumps and tandem pumps.

#### External control handle requirements

Maximum allowable trunnion torque is 79.1 N·m [700 in·lbf] for M25, M35, and M44. Minimum torque necessary to hold the swashplate at a zero angle for neutral is 2.3 N·m [20 in·lbf]. Maximum trunnion angle is 15° for M25 and 16° for M35 and M44.

#### DDC on Left Side of M35 Pump

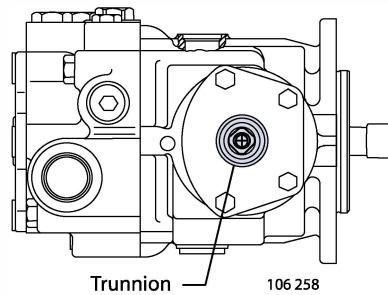

#### Pump Displacement vs Swashplate Rotation

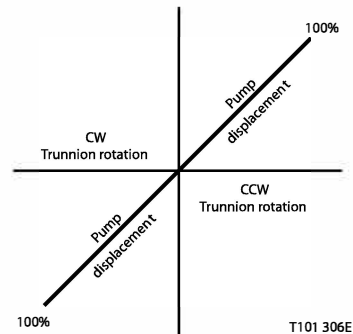

#### DDC input specs

|            |             |          |             |
|------------|-------------|----------|-------------|
| Max torque | Nm [in·lbf] | 79.1     | [700]       |
| Min torque | Nm [in·lbf] | 2.3      | [20]        |
| Max angle  |             | M25: 15° | M35/44: 16° |

#### Pump flow direction

| Input shaft rotation |                 | CW    |     |      |     | CCW   |     |      |     |
|----------------------|-----------------|-------|-----|------|-----|-------|-----|------|-----|
|                      |                 | Right |     | Left |     | Right |     | Left |     |
| Trunnion location    |                 | Right |     | Left |     | Right |     | Left |     |
| Trunnion rotation    |                 | CW    | CCW | CW   | CCW | CW    | CCW | CW   | CCW |
| PV or front PV       | Port A Flow     | Out   | In  | In   | Out | In    | Out | Out  | In  |
|                      | Port B Flow     | In    | Out | Out  | In  | Out   | In  | In   | Out |
| Rear PT              | Port C (A) Flow | In    | Out | Out  | In  | Out   | In  | In   | Out |
|                      | Port D (B) Flow | Out   | In  | In   | Out | In    | Out | Out  | In  |

#### M25 Variable Pump

#### Auxiliary mounting flange

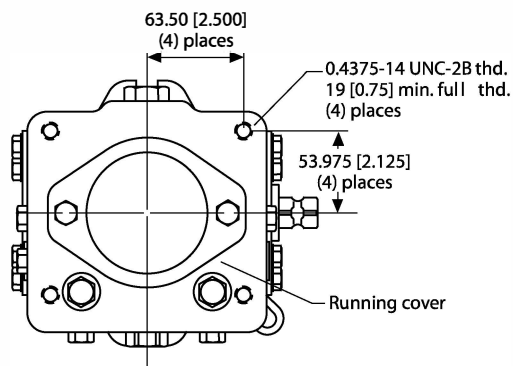

Running cover

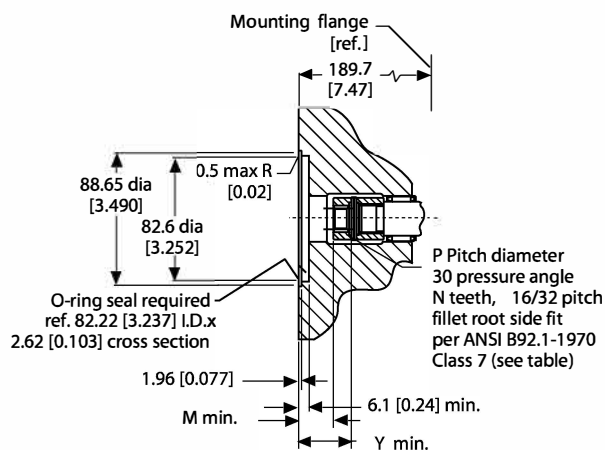

SAE A Auxiliary mounting flange

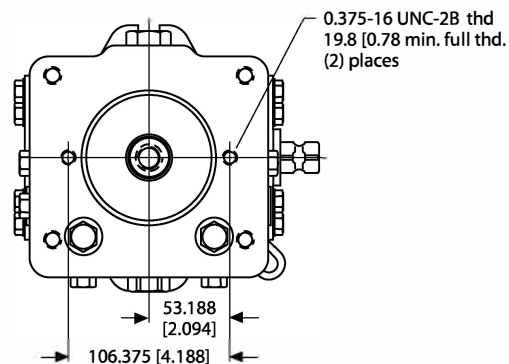

P100 603E

#### M25PV Auxiliary flange coupling options

| Auxiliary mounting flange |          | Spine pitch dia. P | Number of teeth N | Shaft clearance Y | Coupling clearance M |
|---------------------------|----------|--------------------|-------------------|-------------------|----------------------|
| SAE A                     | Option A | 14.30 [0.563]      | 9                 | 34.5 [1.36]       | 22.6 [0.89]          |
| SAE A                     | Option D | 17.46 [0.688]      | 11                | 39.6 [1.56]       | 25.9 [1.02]          |

\*All ports are SAE straight thread o-ring ports per SAE J514, unless otherwise specified.

Shaft rotation is determined by viewing pump from input shaft end.  
Contact your QCC LLC representative for specific installation drawings.

Dimensions in mm [in]



# Series 40 Direct Displacement Pumps

## Technical Information

### Installation Drawings

#### M25 Variable Pump (continued)

#### Pump and control

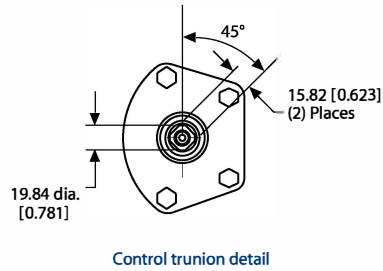
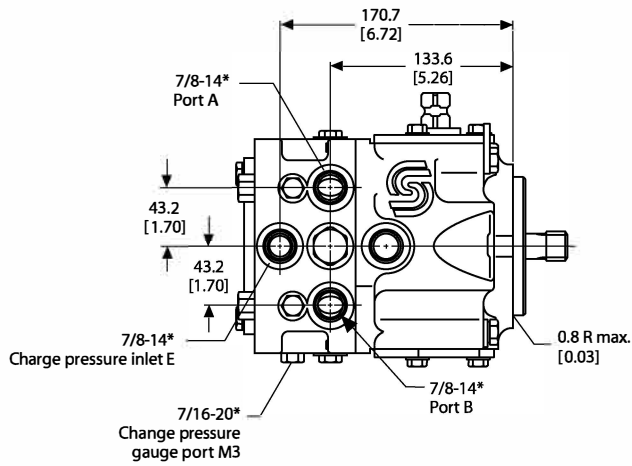
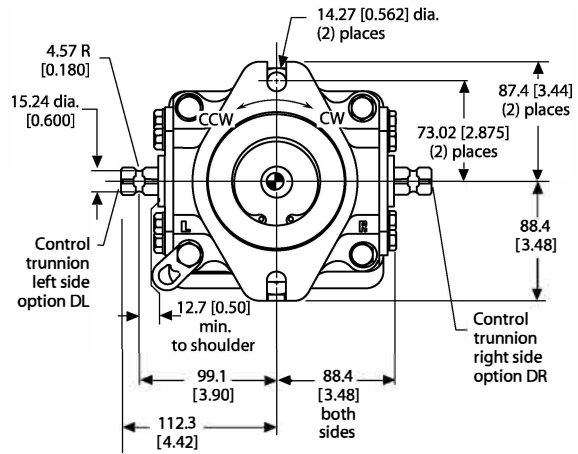
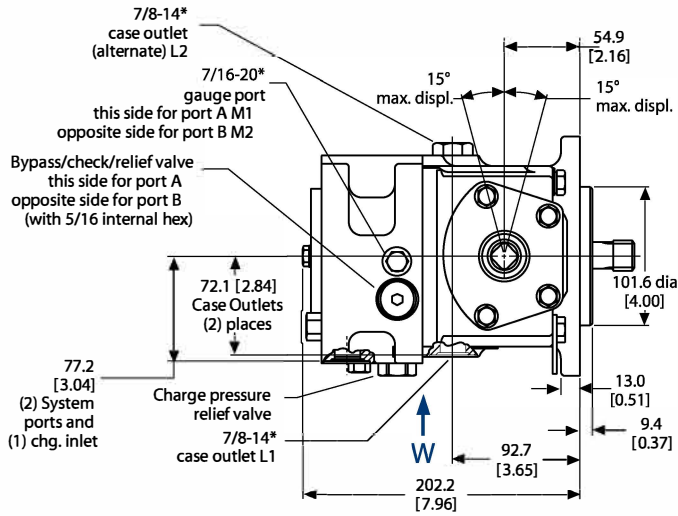

P100 602E

\*All ports are SAE straight thread o-ring ports per SAE J514, unless otherwise specified.  
 Shaft rotation is determined by viewing pump from input shaft end.  
 Contact your QCC LLC representative for specific installation drawings.

Dimensions in mm [in]



**M25 Tandem Pump**

*Auxiliary mounting flange*

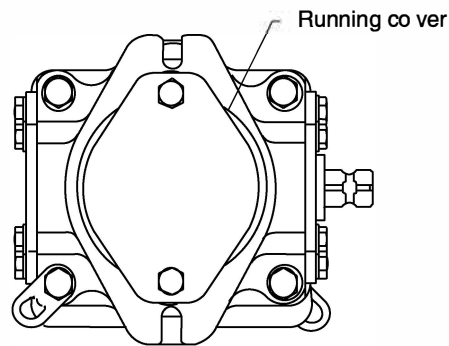

Running cover

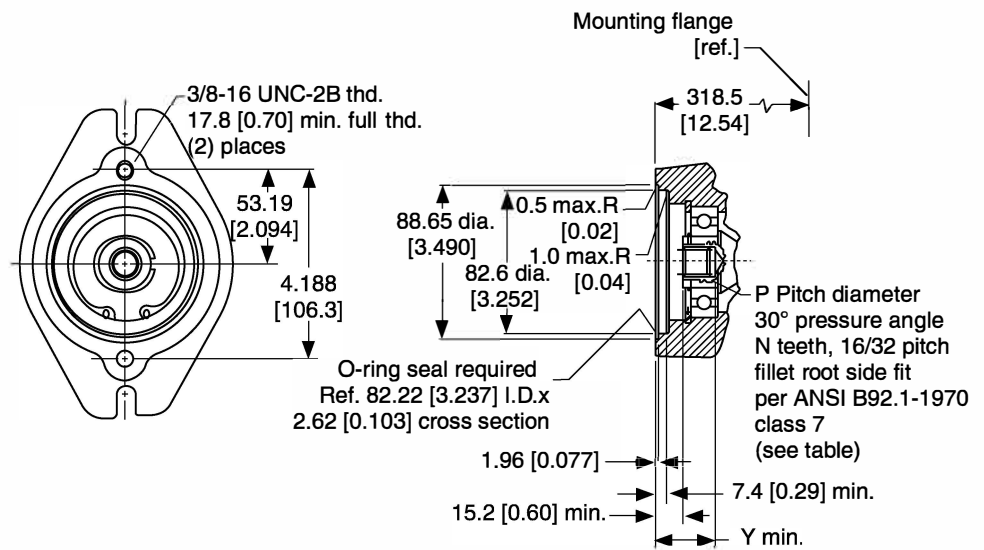

SAE A Auxiliary mounting flange

P100 612E

\*All ports are SAE straight thread o-ring ports per SAE J514, unless otherwise specified.

Shaft rotation is determined by viewing pump from input shaft end.  
Contact your QCC LLC representative for specific installation drawings.

Dimensions in mm [in]



# Series 40 Direct Displacement Pumps

## Technical Information

### Installation Drawings

#### M25 Tandem Pump (continued)

#### Pump and control

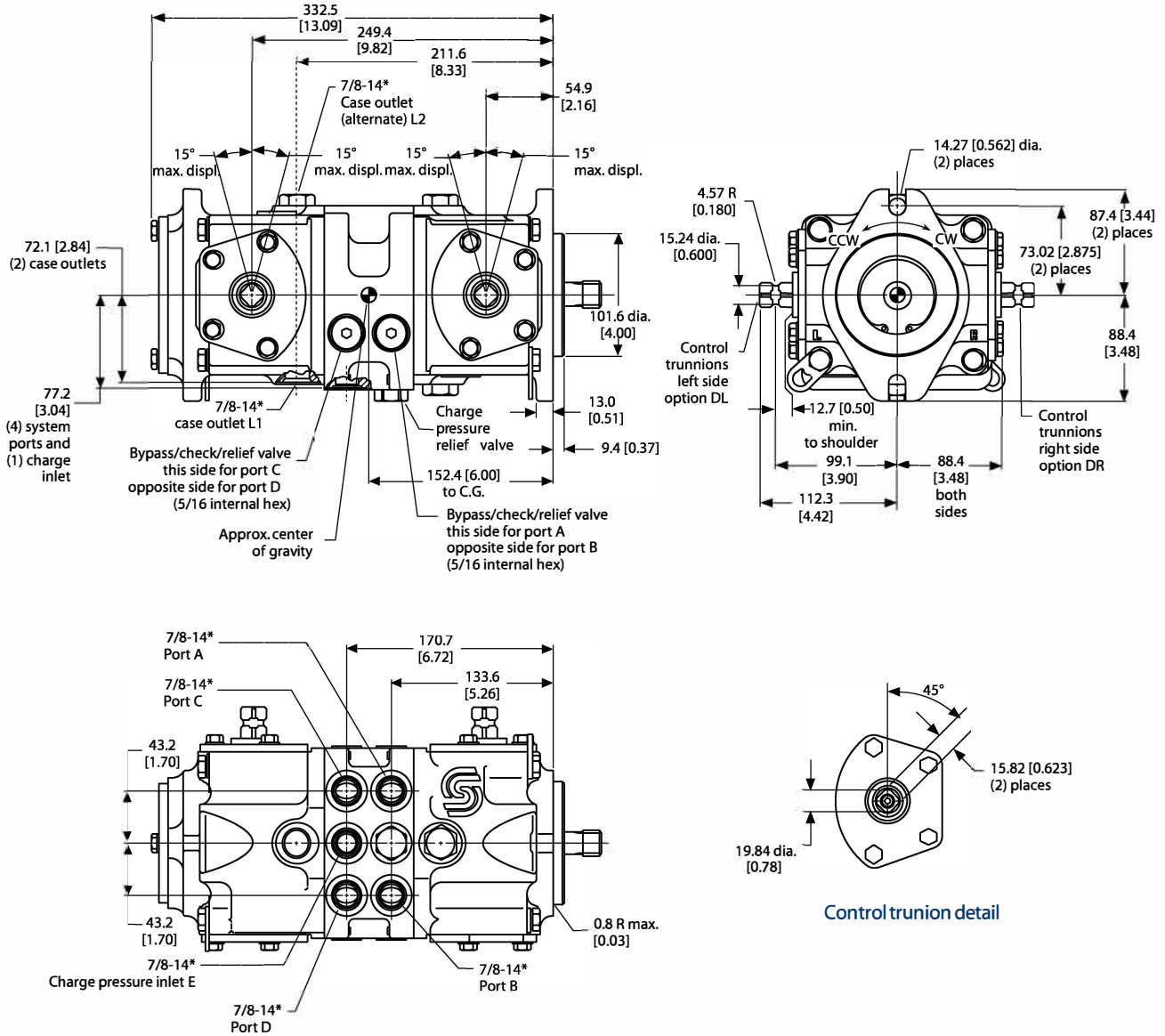

P100 611E

\*All ports are SAE straight thread o-ring ports per SAE J514, unless otherwise specified.  
 Shaft rotation is determined by viewing pump from input shaft end.  
 Contact your QCC LLC representative for specific installation drawings.

Dimensions in mm [in]