

Directional Control Valve Load Sense Pressure Compensated MP18

RA 64 965/01.05 1/20

Replaces: 10.96

Series 30

Nominal pressure 3625 psi (250 bar) pump side
Nominal pressure 4200 psi (290 bar) actuator side

Max. flow

– pump side:

- 40 GPM (150 l/min) unloading and priority inlet element
- 50 GPM (189 l/min) standard closed center inlet element

– actuator side:

- 35 GPM (133 l/min) consult factory for higher flow rates



Functional Description

MP18, series 30 mobile stack type valves are load sensing pressure compensated valves. They control the volume, direction of oil flow and maintain a constant flow regardless of changing load pressures.

An advantage of the MP18 is that the starting point for movement of the function always remains the same, i.e., a specified control spool position always has the same metering characteristics. This is accomplished by a compensating spool in each section.

While the main spool is in neutral, the primary shuttle and secondary shuttle are vented to tank. When the main spool is operated, the load pressure is directed via the primary shuttle to the spring end of the pressure compensator spool. The section compensator now moves to the open position. Dependent on the pressure drop between the section compensator and the control spool opening, a specific volume now flows to the function. The load signal also simultaneously communicates to the secondary shuttle and on to the system compensating device. The system compensating device can be either an inlet compensator (open center unloading inlet) in the case of a fixed pump system or a pump compensator control in the case of a variable pump system.

Features

- Parallel and series parallel type valve with wide range of section circuitry including 3-way, 4-way, float, motor control, 3 position and priority. Available with both flow and pressure control spools.
- May be combined with MP18 series 10 sections to provide series parallel circuitry.
- Section compensator allows each section to operate at a predetermined flow rate independent of pump discharge flow and pressure.
- Low spool operating forces possible by elimination of series by-pass circuits through the valve. This lends itself to remote operation of valve spools.
- Variety of main spool operators including manual, hydraulic, electro-hydraulic (proportional or on-off control), and mechanical detents. Electro-hydraulic and hydraulic remote also available with manual handle override.
- Section with pressure regulator or remote regulator port allows each section to operate at a predetermined maximum pressure level independent of pump discharge pressure.
- Low neutral pressure drop with open center inlet section, pressure drop remains constant regardless of number of sections. Pump discharge flow is directed back to the reservoir at low pressure through the unloading valve located within inlet section.
- Primary relief in open center unloading inlet section and priority port relief in priority inlet section which provides accurate pressure control over a wide flow range

Ordering Code

Fluid

Petroleum oil (For operation with other fluids, consult a Rexroth Application Engineer)

MP 18-30 / /

Number of Sections

Directional control sections (8 sections maximum)

Directional Control Valve

Mobile stack valve, pressure compensated, Series 20 **MP 18**

Inlet () Indicate required pressure in bar.

Standard closed center inlet	C	Closed center priority ①	P()
Closed center top port	CT	Open center ①	O()
Closed center top ported with spike relief ①	CG()	Open center with back pressure check ①	OB()
Closed center top ported with plug ①	CQ	Open center with power beyond ①	OP()

Directional Control Section

High Boy Section	HB	High Boy Regenerative	HBR
High Boy Priority	HBP		

Schematic Designation () Indicate limited flow in liters/minute after spool schematic designation.

1 2 3 4 5 6 7 8 9 10 11 12 13 14 16

All spool designations, except number 6, 10, and 16, are available with flow limited main spools for improved metering characteristics. If flow limited spool is required, add in () the flow in liters/min. after the spool designation. Available flow limited main spools are; 7 gpm (34 lpm), 11 gpm (42 lpm), 15 gpm (57 lpm) and 24 gpm (91 lpm). Consult factory for special customer requirements in main spool design if quantities are justified.

Spool Operation () Indicate required DC voltage (12v or 24v) or pressure release detent setting in bar.

Spring centered	A	Hydraulic pilot operated	H
Spring centered with stroke limiter on A & B	A1	Hydraulic pilot operated with stroke limiters ②	H1()
Spring centered with stroke limiter on A	A2	Hydraulic pilot operated with manual handle override	H2
Mechanical detent A and B	B	Electrical proportional control	L()
Spring centered from A mechanical detent B	B1	Electrical proportional control with stroke limiters ③	L1()
Spring centered from B mechanical detent A	B2	Electrical prop. control with manual handle override ④	L2()
Spring centered from A & B mechanical detent float	B3	Electrical on/off control	M()
Multi-position detent	B4	Electrical on/off control with stroke limiters ⑤	M1()
Mechanical detent A, B, and float	B5	Electrical on/off control with manual handle override ⑥	M2()
Mechanical detent A and float spring centered from B	B6		

Port Options () Indicate the required secondary relief setting in bar.

Pilot operated relief & anti-cavitation check valve	G()
Proportional combination pilot operated relief & anti-cavitation check valve	P()
Anti-cavitation check valve	E
Machined for port option, with plug	Q

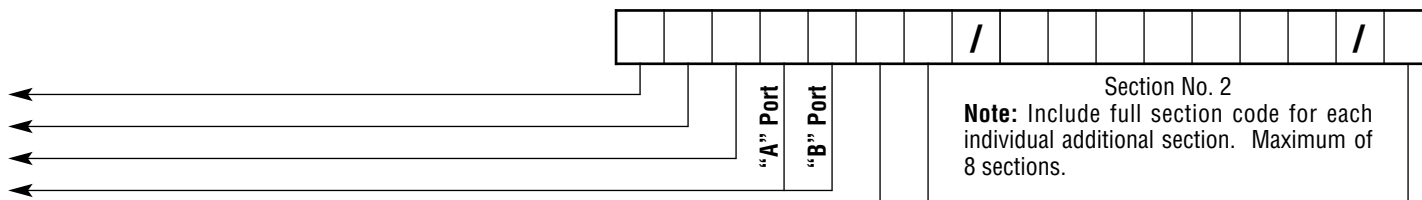

Compensator Option

Standard Compensator	0
Adjustable flow control	1
Fixed-flow hollow compensator. Specify flow in liters/min.: 5 gpm (19 lpm), 10 gpm (38 lpm), 15 gpm (57 lpm), 20 gpm (76 lpm) ⑤	2
Load check	3

Section Compensator Pressure Control Option (___) *Indicate required settings in bar.*

No compensator pressure control (standard)	A
Compensator pressure regulator	B(___)
Port for remote compensator pressure regulation ④	C

End Cover

Standard end cover	L
End cover with pressure reducing valve integral for electro-hydraulic controlled sections.	Q
End cover with external supply pressure port for electro-hydraulic controlled sections.	R
End cover with pressure regulator for pilot supply port.	S
To add P, T or LS ports to end cover, add P, T or L in (___) after end cover codes L, Q, R or S. <i>Example: L(PTL) would indicate a pressure, tank and load sense carry over ports in the end cover.</i>	(___)

- ① Please consult factory when ordering.
- ② H1(___) designate which ports are to be stroke limited (A, B, or A & B).
- ③ All electrical main spool operation codes (L, L1, L2, M, M1, M2) must be sold as complete valve assemblies.
 Codes L1 or M1 designate stroke limiter. Specify which ports are to be stroke limited (A, B, or A & B).
 All electrical sections must be assembled in line from end cover Q or R.
- ④ Compensator pressure options (B, or C) not available in all section assemblies.
 Not available when spool operation codes B–B6 or when used in conjunction with secondary work port options.
 Port for remote compensator pressure regulation not available in electrical solenoid operated sections.
- ⑤ Not available in HBP sections.

Technical Data

MP18 Specifications

Flow range	GPM (L/min)	35 (133)	Note... Consult factory for higher flow rates
Primary operating pressure	Port T PSI (bar)	290 (20)*	
	Port P PSI (bar)	3625 (250)*	
Secondary relief valve setting	Port A, B PSI (bar)	4200 (290)*	
Hydraulic fluid		Petroleum oils (HM, HL, HLP)	
Fluid temperature range	° F (° C)	t _{min} = -4° F (-20)	t _{max} = 158° F (70)
Viscosity range	SSU (mm ² /s)	35–1760 (10–380) (dependent upon fluid)	
Cleanliness level		18/15 according to ISO 4406	

*For applications outside these parameters, please consult Rexroth

Installation Dimensions

**Model...2MP18-30/O(250)/
HBP1AG(262)G(262)1A/
HB1L(12)G(262)G(262)OA/
Q**

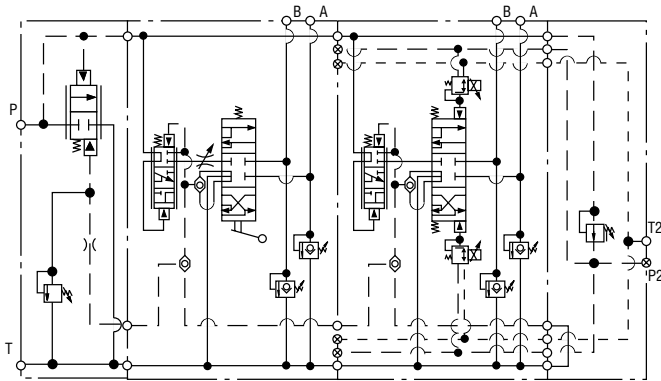
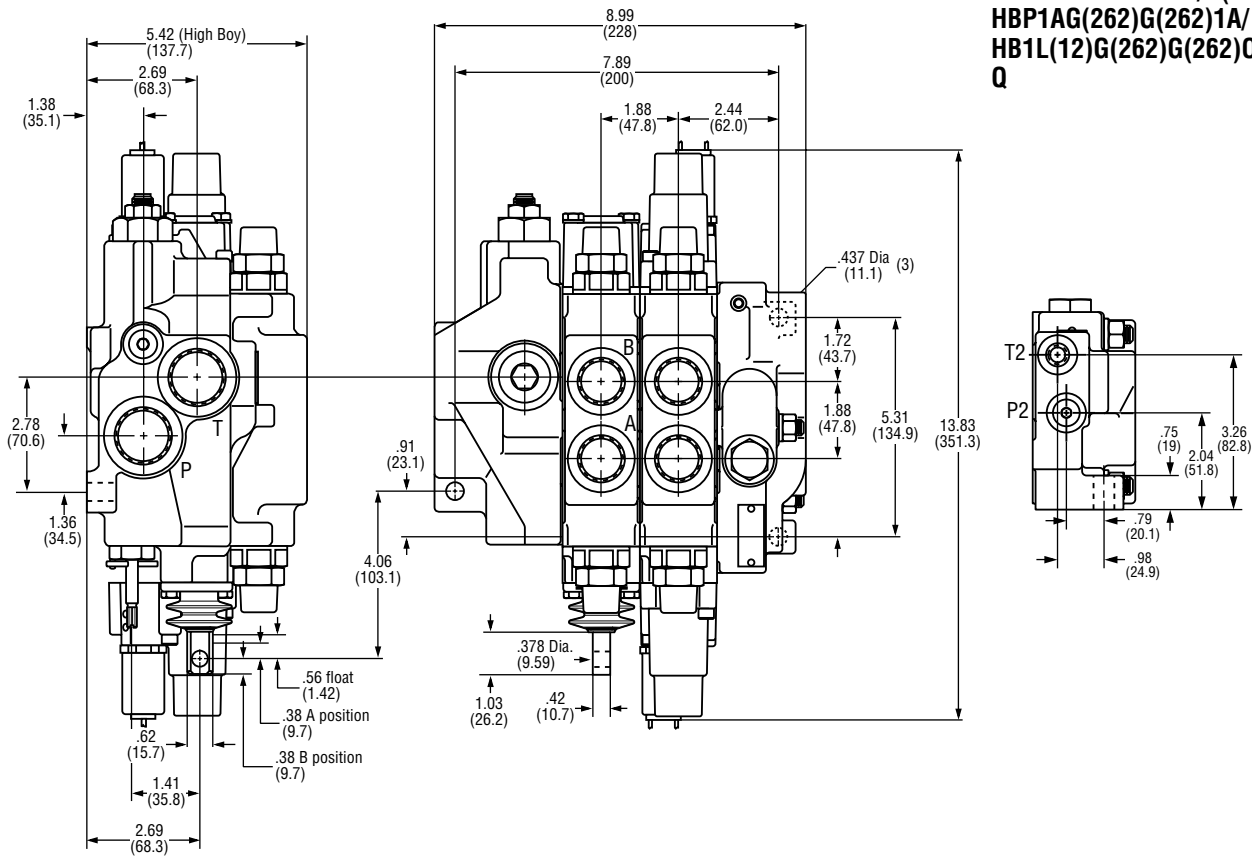

Regen and Top Ported Closed Center Inlets with Standard End Cover

Number of Directional Control Spools	Overall Length		Bolt Hole Centers	
	A		B	
	inches	millimeters	inches	millimeters
1	6.60	167.6	5.79	147.0
2	8.48	215.3	7.67	194.7
3	10.36	263.0	9.55	242.5
4	12.24	310.77	11.43	290.2
5	14.11	358.5	13.30	337.9
6	15.99	406.2	15.18	385.7
7	17.87	454.0	17.06	433.4
8	19.75	501.7	18.94	481.1

Closed Center Inlet with Standard End Cover

Number of Directional Control Spools	Overall Length		Bolt Hole Centers	
	A		B	
	inches	millimeters	inches	millimeters
1	5.70	144.8	4.88	124.0
2	7.58	192.6	6.76	171.7
3	9.46	240.3	8.64	219.5
4	11.34	288.0	10.52	267.2
5	13.22	335.7	12.40	314.9
6	15.10	383.5	14.28	362.6
7	16.98	431.2	16.16	410.4
8	18.86	478.9	18.04	458.0

Priority and all Open Center Inlets with Standard End Cover

Number of Directional Control Spools	Overall Length		Bolt Hole Centers	
	A		B	
	inches	millimeters	inches	millimeters
1	6.86	174.3	6.01	152.6
2	8.74	222.0	7.89	200.3
3	10.62	269.8	9.77	248.0
4	12.50	317.5	11.64	295.8
5	14.38	365.2	13.52	343.5
6	16.26	412.9	15.40	391.2
7	18.14	460.6	17.28	438.9
8	20.02	508.3	19.16	486.6

Installation Dimensions

Model...2MP18-30/C/
HB1HZZ0A/
HB1BZZ0A/
L

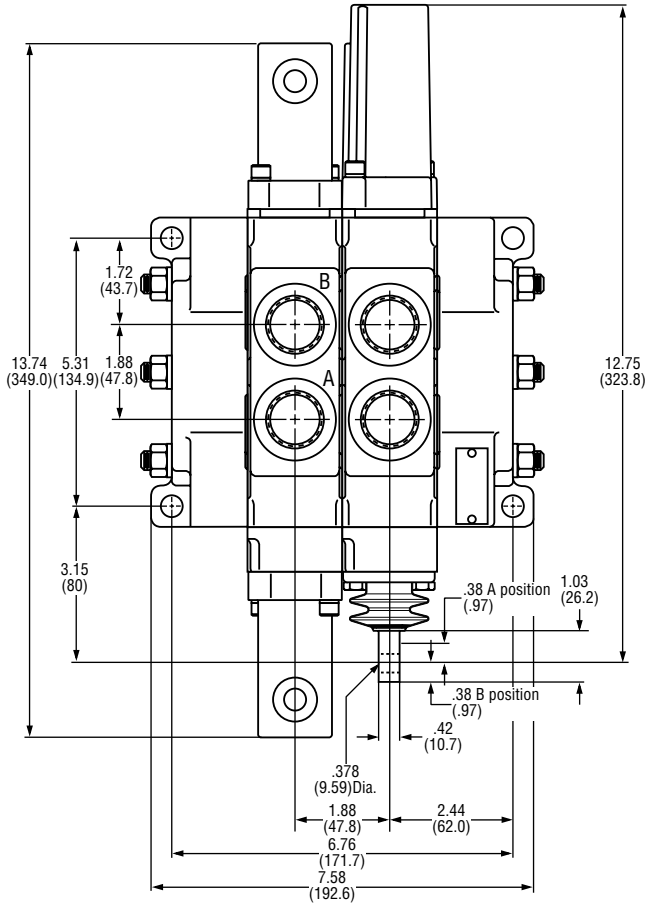
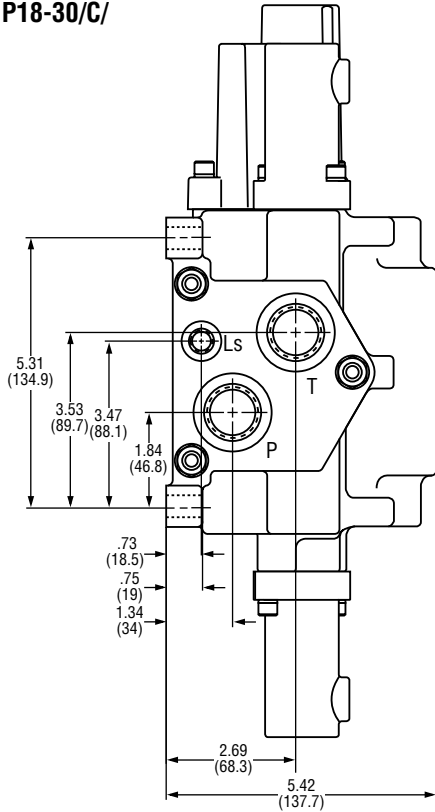

Standard Port Sizes (SAE)

Inlet	P...Inlet	T...Tank	PB	PR	LS	PRLS
C	#12	#12			#6	
C	#16	#16			#6	
CG	#16	#16			#6	
CQ	#16	#16			#6	
P	#16	#16		#12, 8, 6	#6	#6
O	#16	#16				
OB	#16		#12			
OP	#16	#16	#12			
Work Section	A Work Port	B Work Port				
HB	#12	#12				
HBP	#12	#12				
HBR	#12	#12				
End Covers	P...Inlet	T...Tank	LS...Load Sense	P2...Pilot Supply	T2...Pilot Drain	
L(PTL)	#12	#12	#4			
L(PTL)	#16	#16	#6			
Q(PTL)	#16	#16	#6		#4	
R(PTL)	#16	#16	#6	#4	#4	
S(PTL)	#16	#16	#6	#4	#4	
Hydraulic Housing #4 or #6						

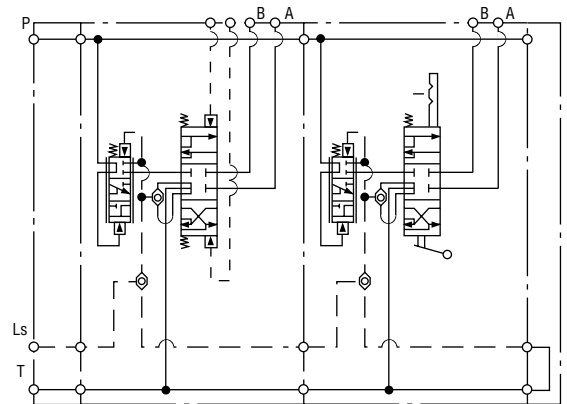

Note: If stack valve assembly has one of the optional end covers (Q, R, or S) the overall length is .250 inches (6.35 mm) longer than the matching valve assembly with standard end cover. Bolt hole mounting dimensions do not change.

Inlets

Open Center Unloading Inlet

Code...0

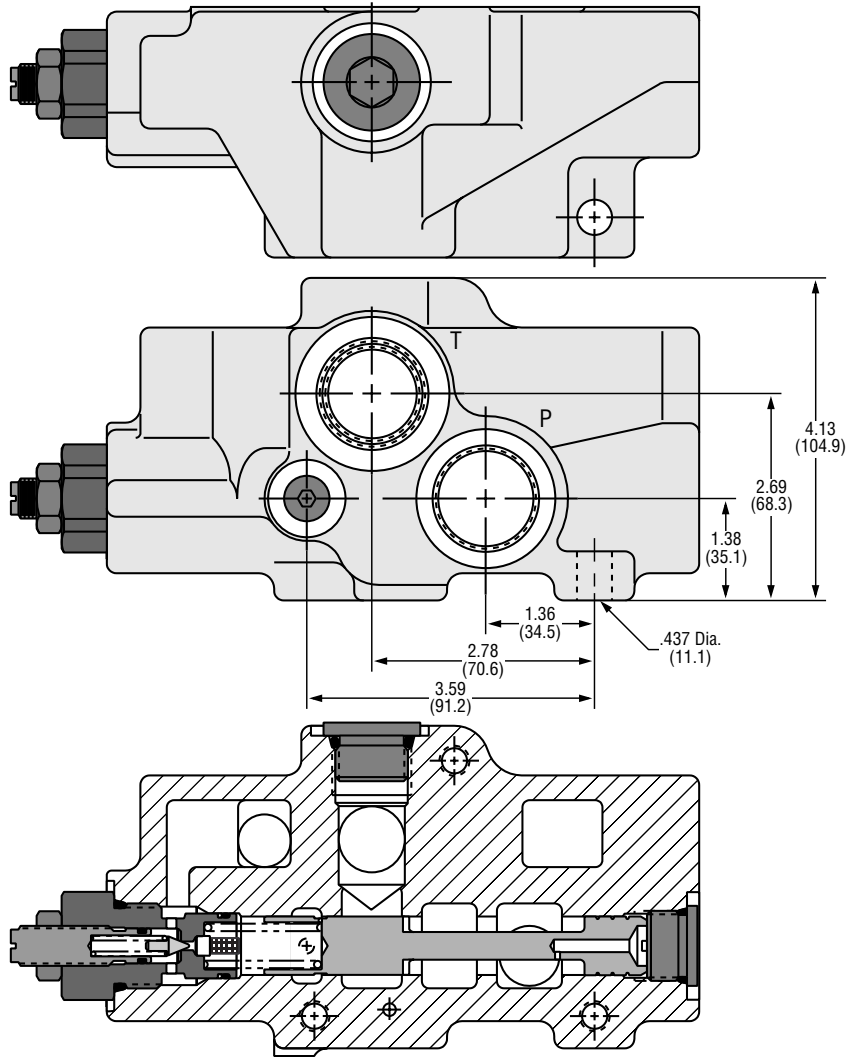

Neutral Pressure Drop
(Open Center Inlet)

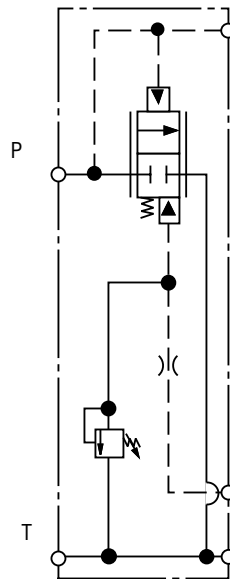
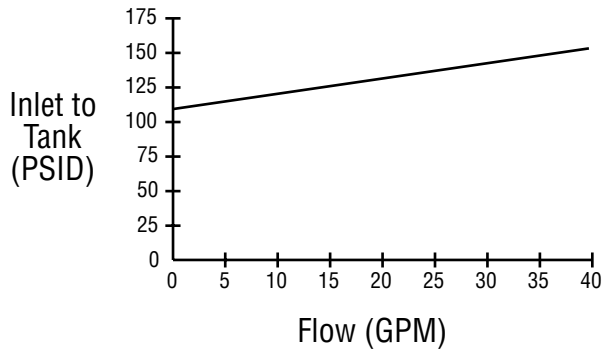

Inlets

Open Center Unloading Inlet with Power Beyond

Code...OP

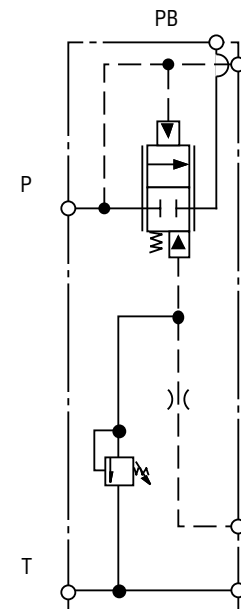
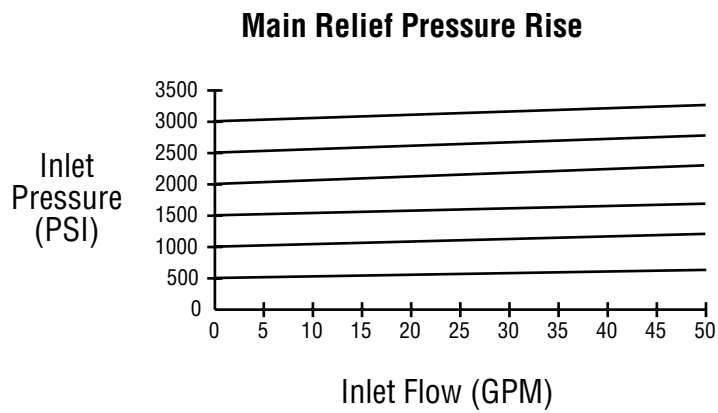
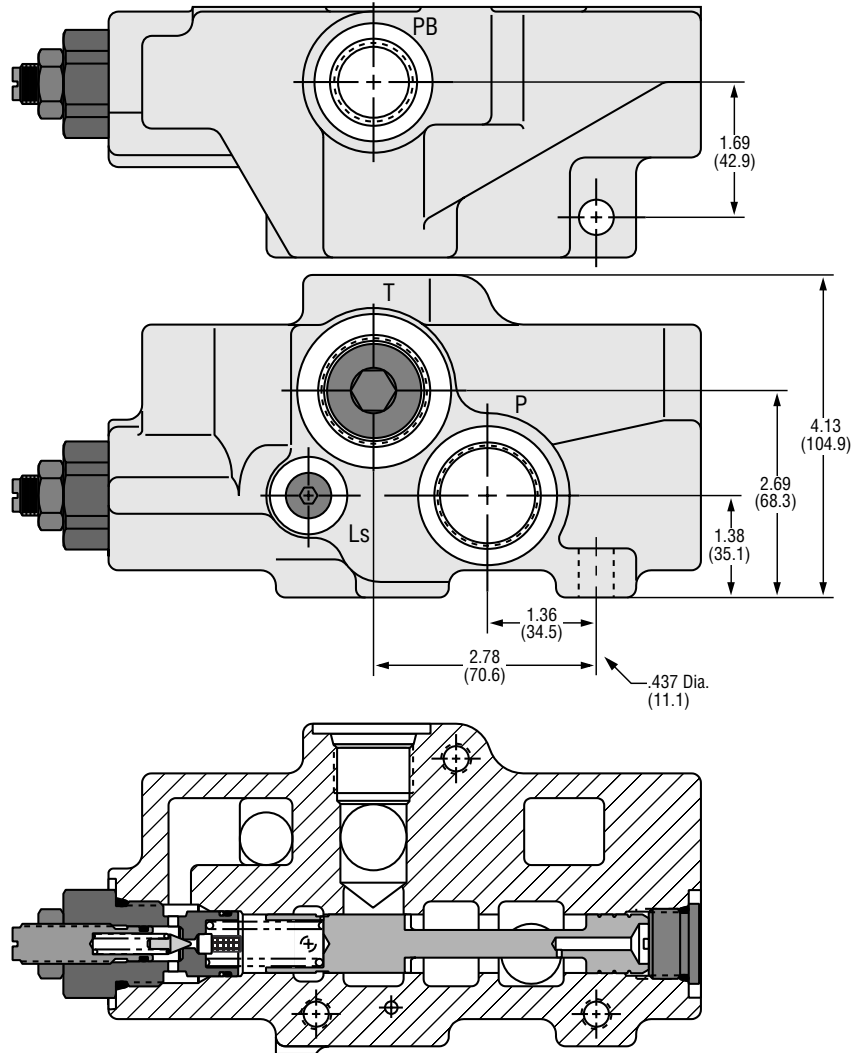

Inlets

Open Center Unloading Inlet
with Back Pressure Check

Code...OB

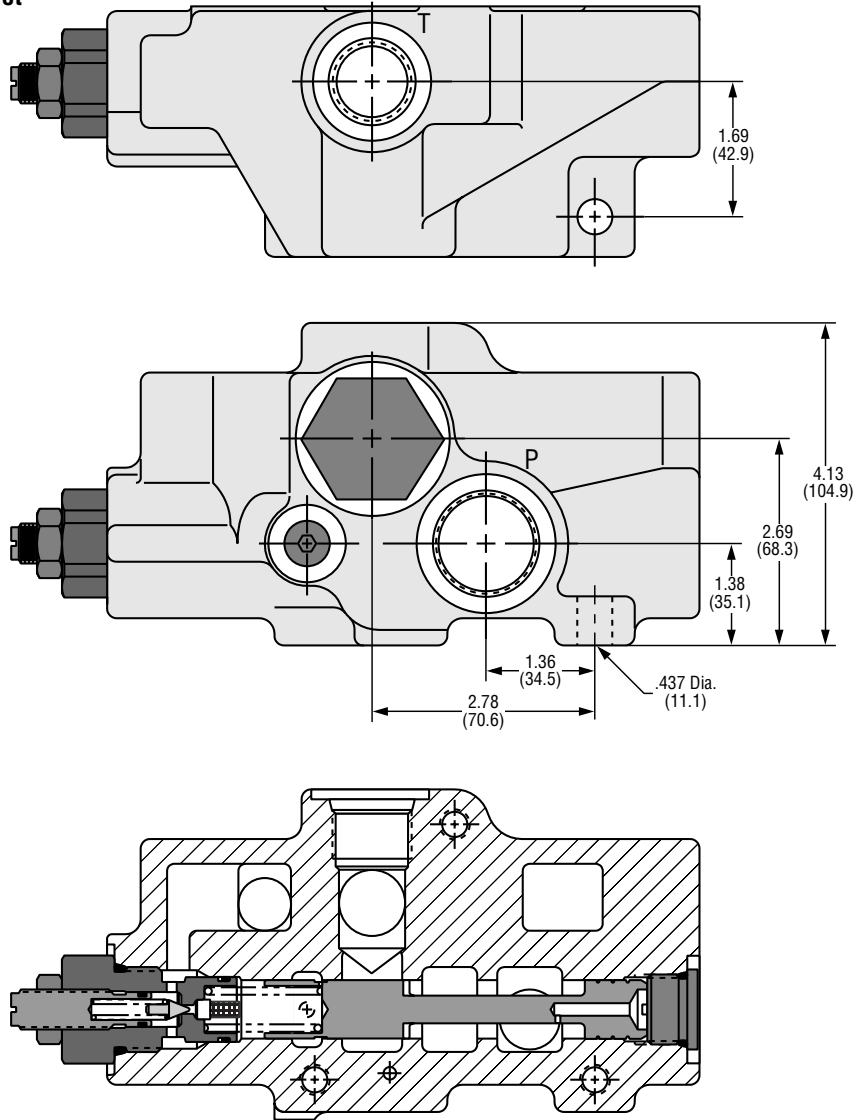

Back Pressure Check

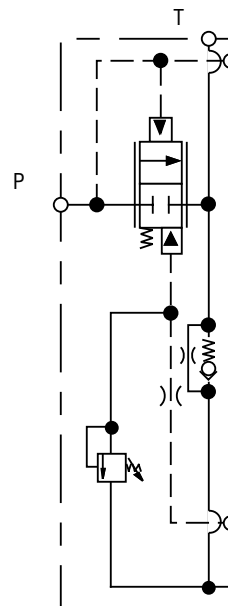
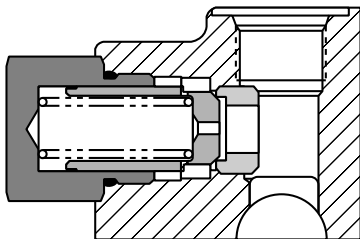

Inlet

Closed Center Priority Inlet

Code...P

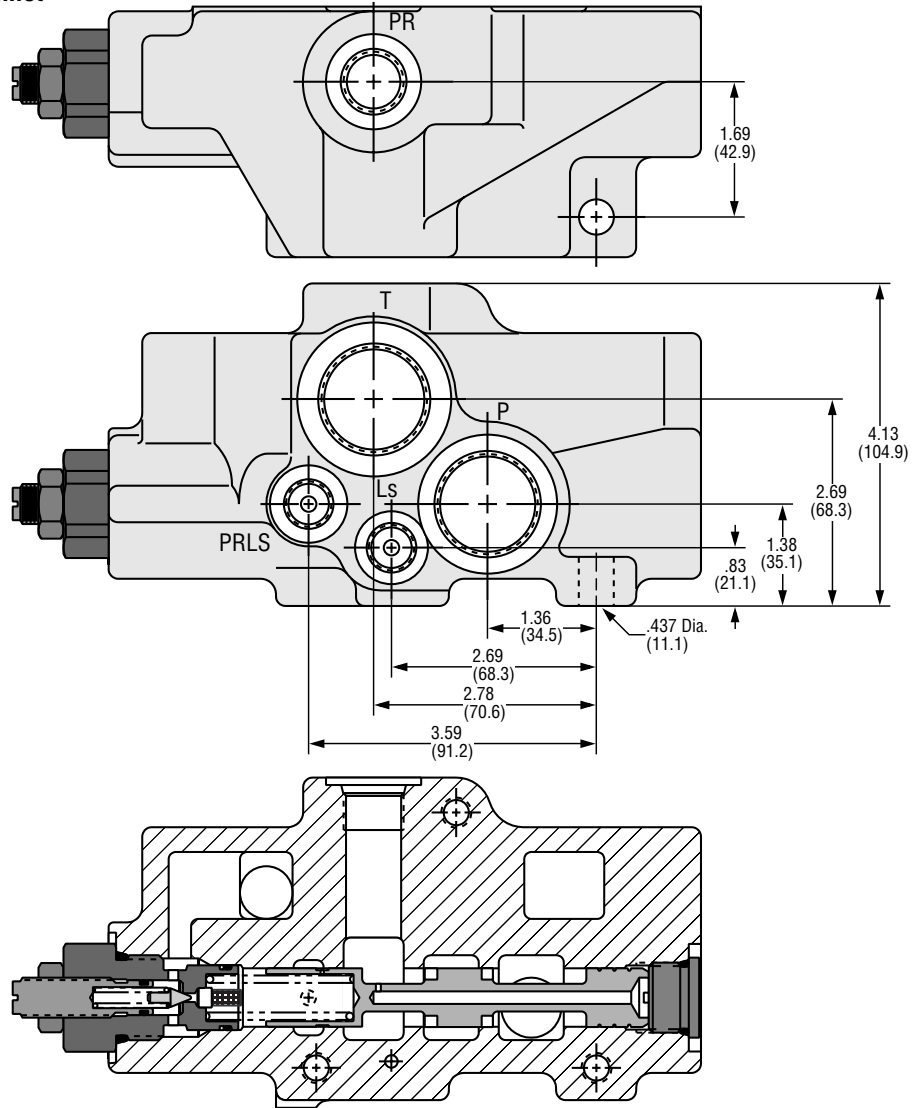

Dynamic Bleed

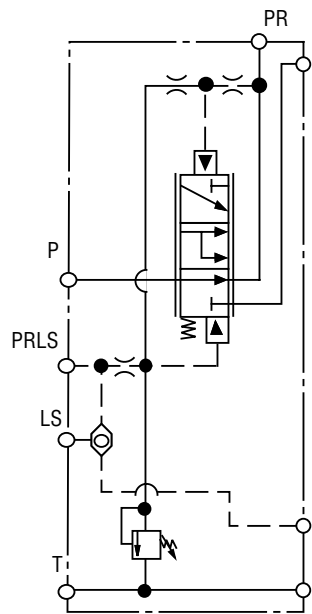

Standard Priority

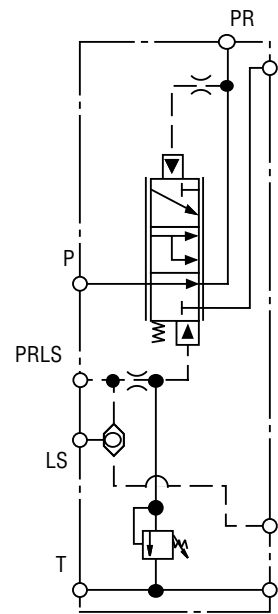

Inlet Options

Standard Closed Center Inlet

Code...C

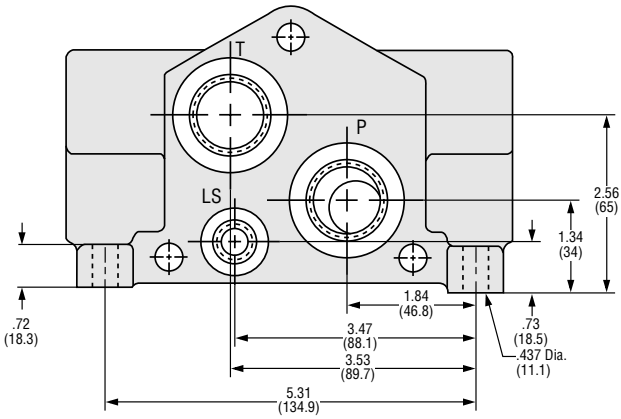

Closed Center Top Ported Inlet

Code...CT

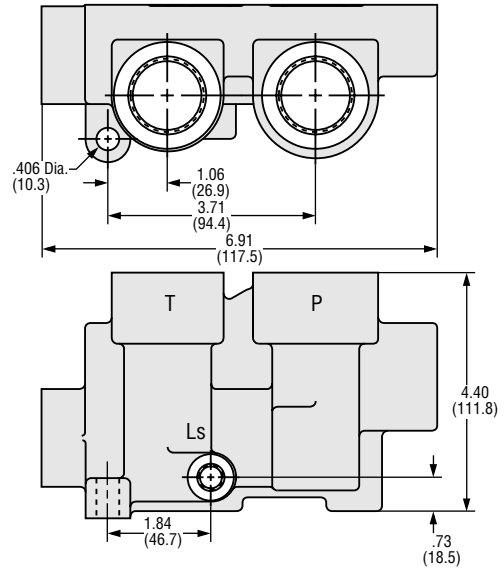

Closed Center Inlet with Spike Relief

Code...CG()

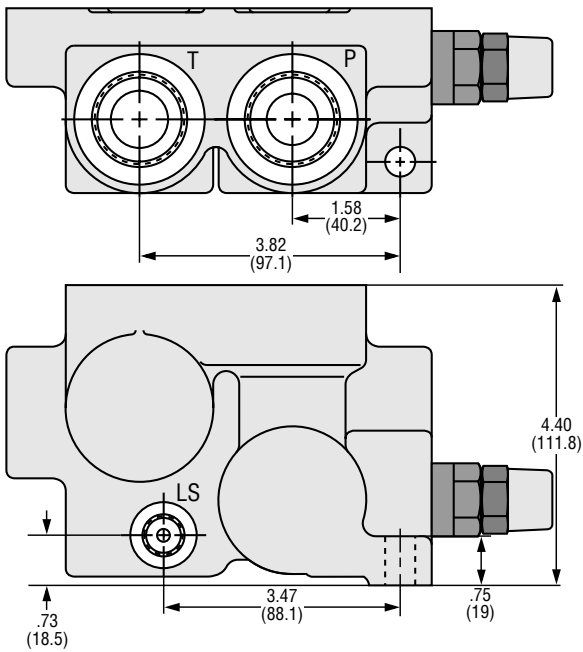

Closed Center Top Ported Inlet

Code...CQ

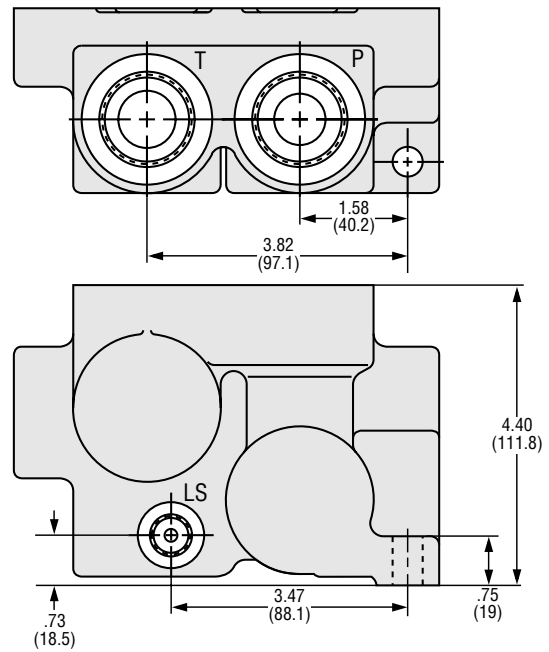

Sectional View

Model...MP18-30/HB1AQQ2(57)A

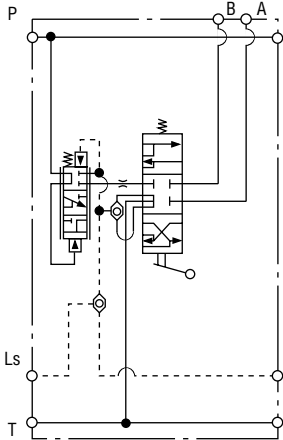
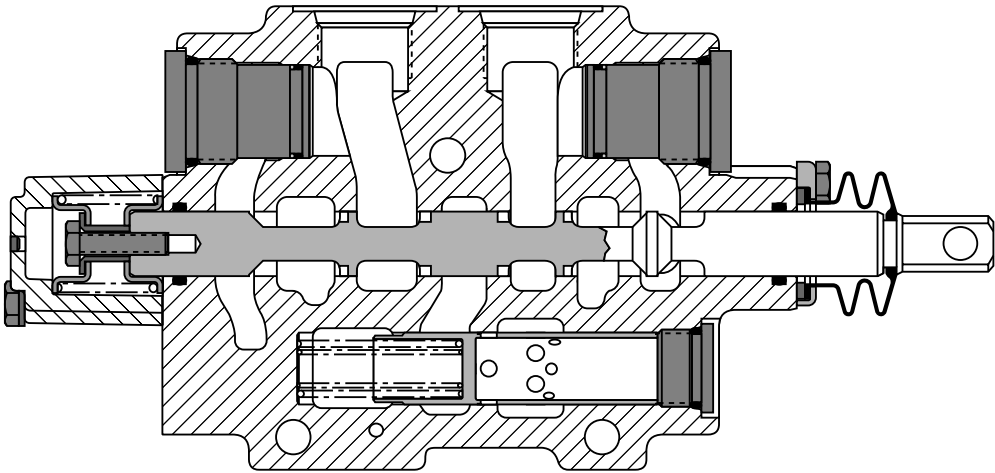

Model...MP18-30/HB3HEQ0B(103)

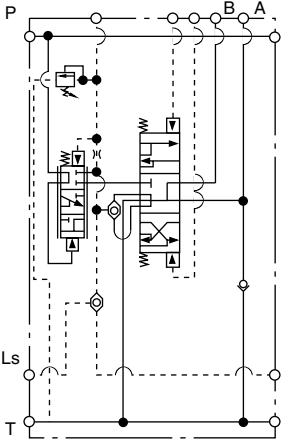
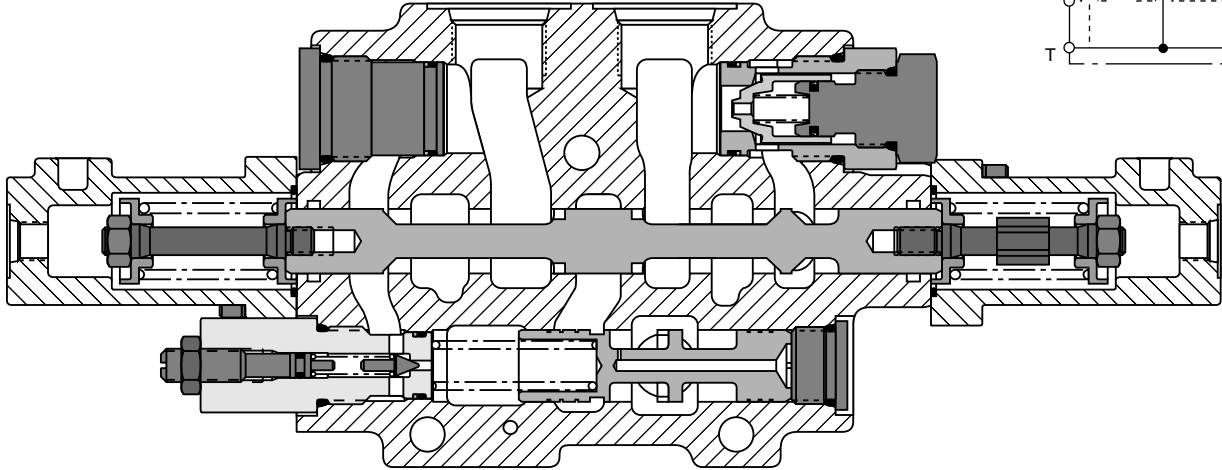

Sectional View

Model...MP18-30/HB3(42)L1QG(203)0A

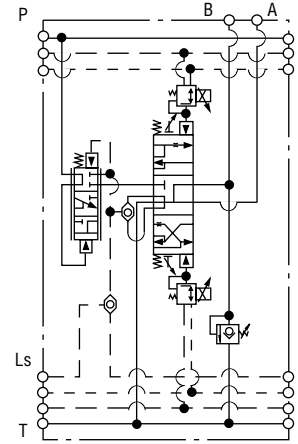
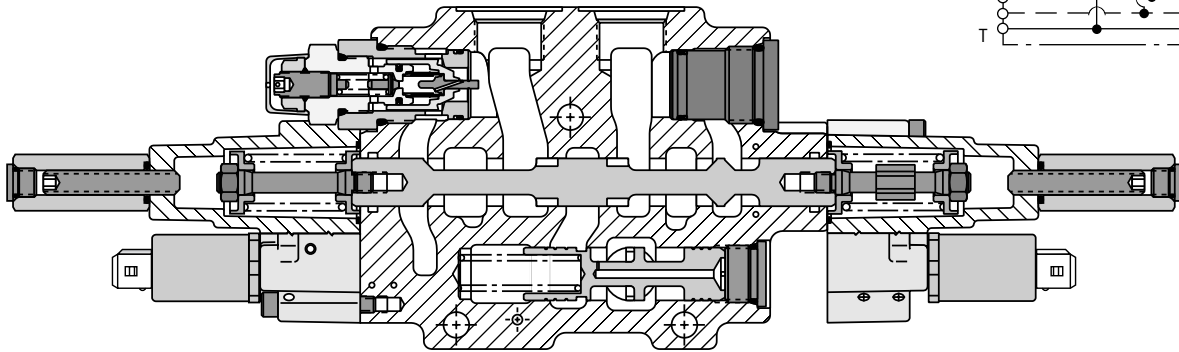

Model...MP18-30/HBP1AG(250)G(250)0A

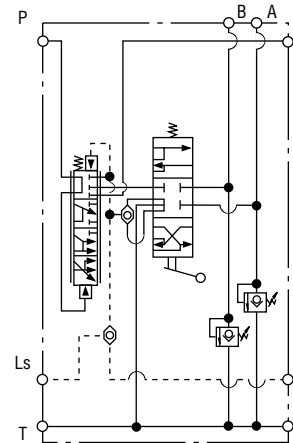
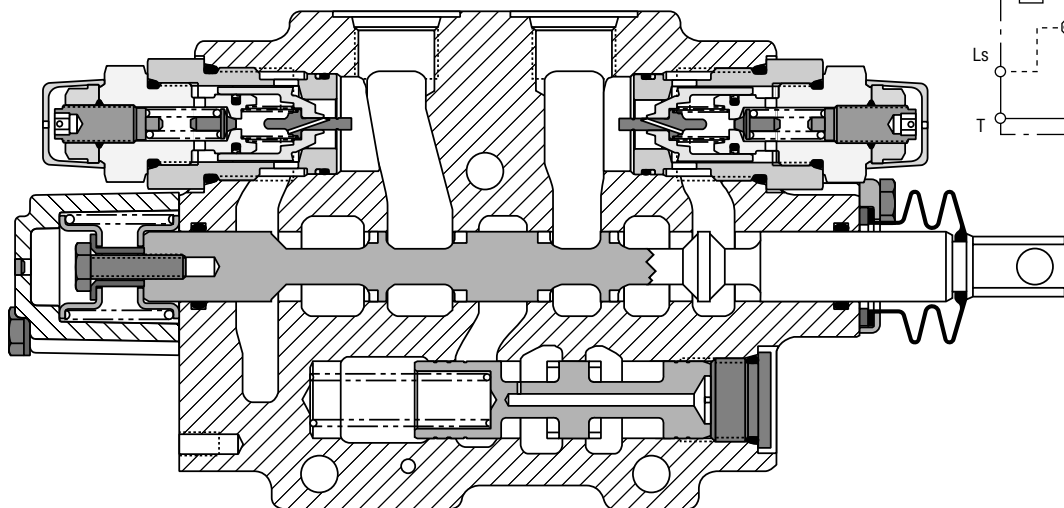

Sectional View

Model...MP18-30/HB16HP(150)P(150)0C

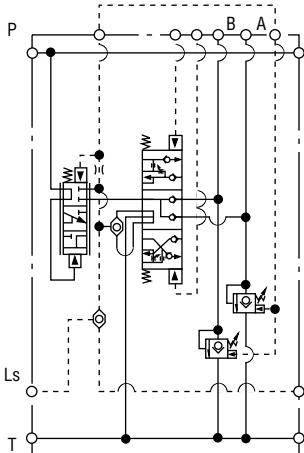
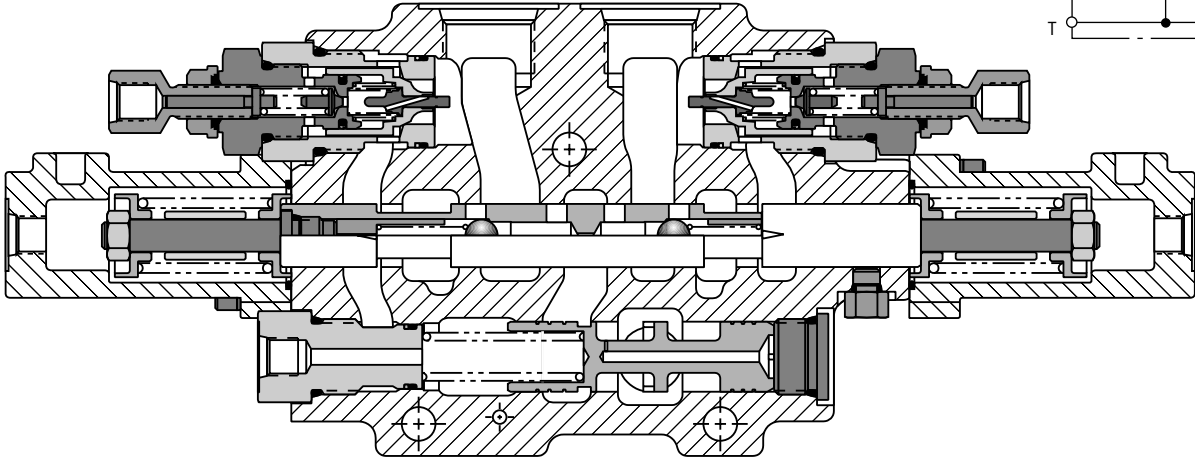

Operating Curves

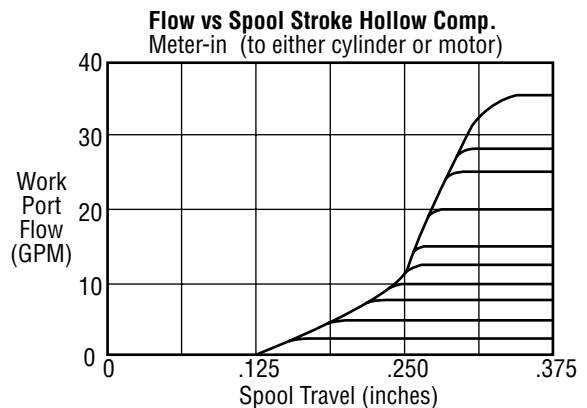
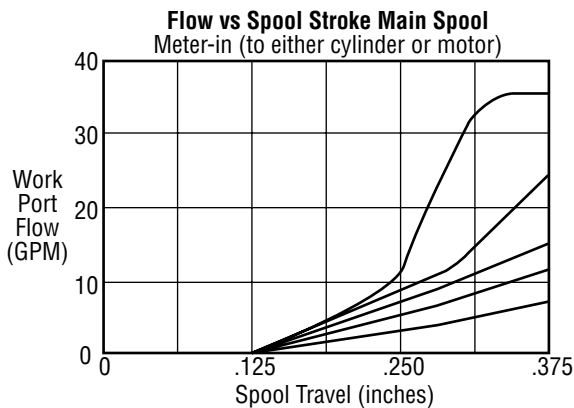
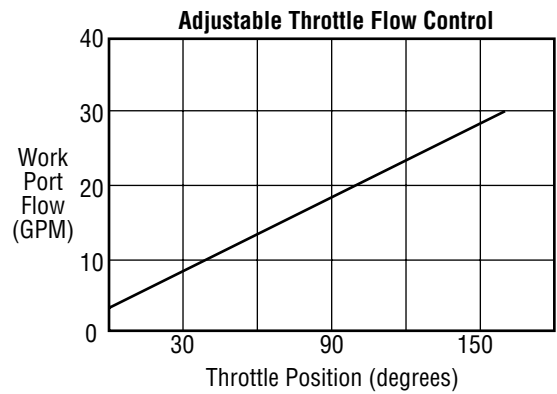
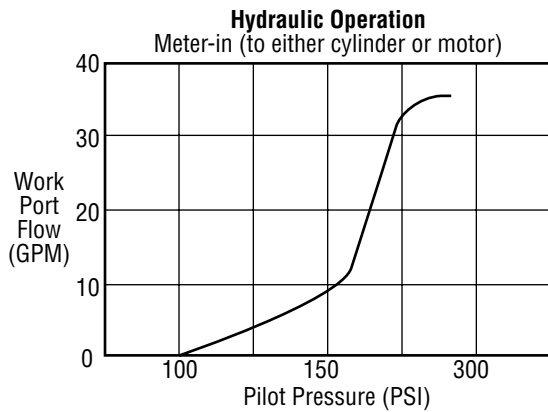
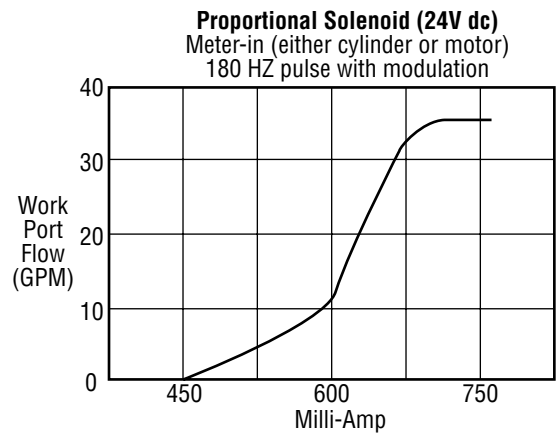
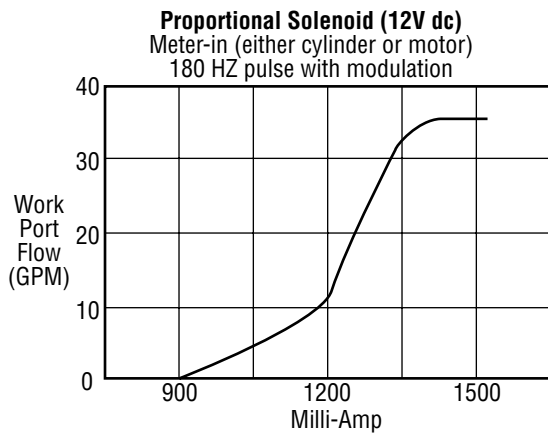
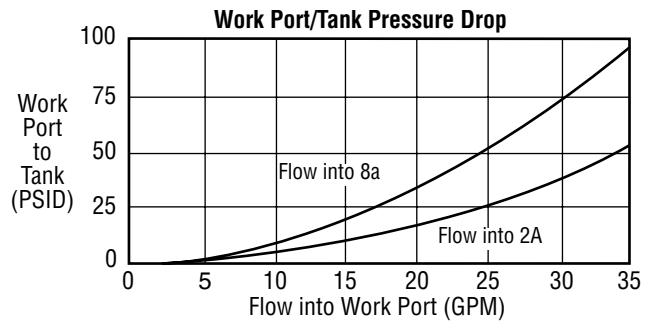
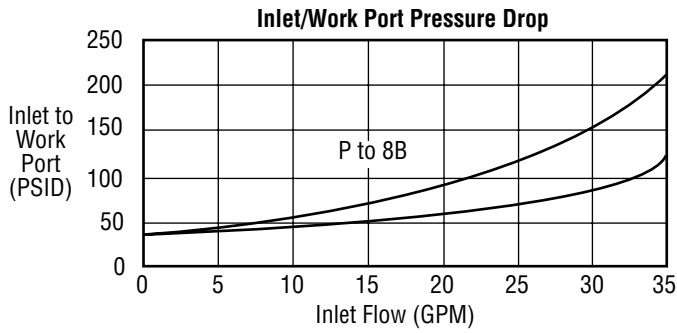

Spool Operation

Electrical Proportional and On/Off Control

Main Spool Operator Codes...L(12), L(24), M(12), M(24).

3 Position Assembly

Internal assembly typical. Housings are not interchangeable. They must be assembled to their proper ends of the sections. Assembly for "A" port end of section

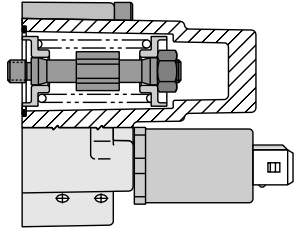

Hydraulic Operated Proportional Control

Main Spool Operator Code...H

3 Position Assembly

Housings are interchangeable from "A" to "B" end of section. Assembly for "A" port end of section.

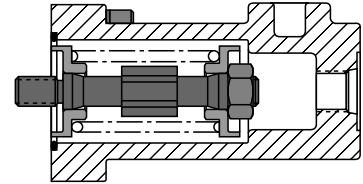

4 Position Assembly

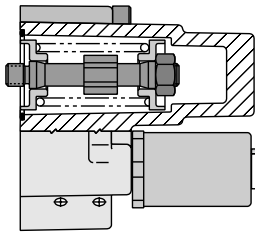

Assembly for "A" port end of section

Assembly for "B" port end of section

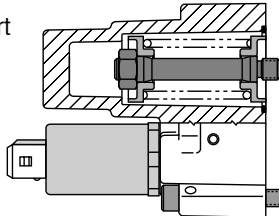

4 Position Assembly

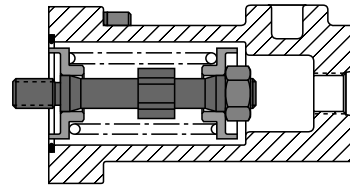

Assembly for "A" port end of section

Assembly for "B" port end of section

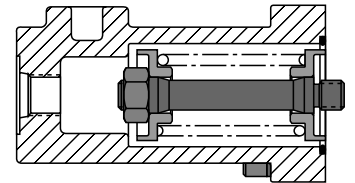

Electrical Proportional and On/Off Control with Stroke Limiter

Main Spool Operator Codes...L1(12), L1(24), M1(12), M1(24).

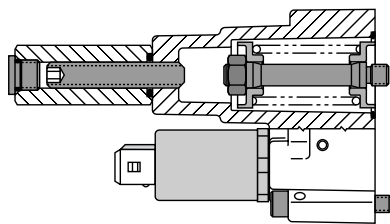

Hydraulic Proportional with Stroke Limiter

Main Spool Operator Code...H1

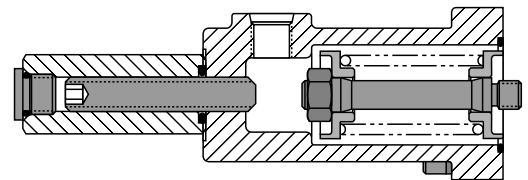

Manual Spring Centered

Main Spool Operator Code...A

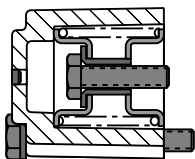

Manual Spring Centered with Stroke Limiter

Main Spool Operator Code...A1

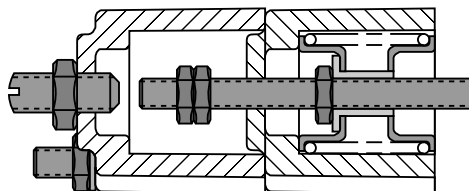

Manual Spring Centered with Stroke Limiter

Main Spool Operator Code...A2

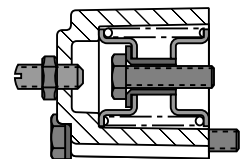

Spool Operation

Electrical Proportional and On/Off Control with Manual Override

Main Spool Operator
Codes...L2(12), L2(24), M2(12), M2(24)
"B" port assembly
Kit P/N 1602-635-096

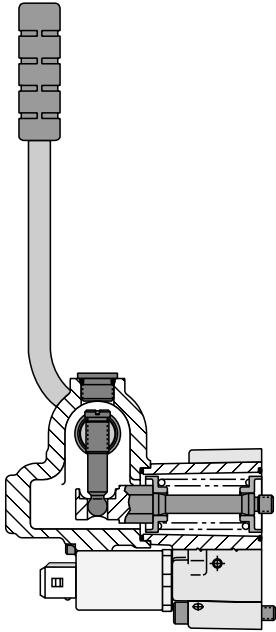

Hydraulic Control with Manual Override

Main Spool Operator Code...H2
"B" port assembly
Kit P/N 1602-635-097

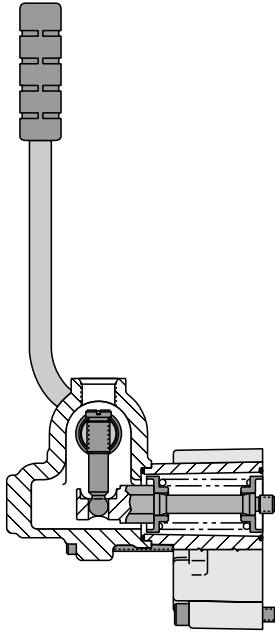

Lever and Dust Boot Assembly

Kit P/N 1601-635-040

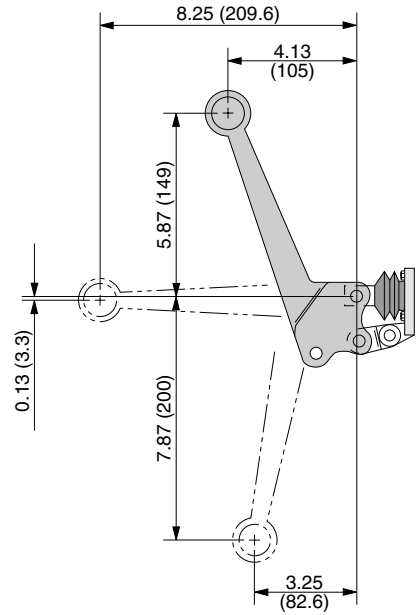

3 Position Detent Assembly Code...B3

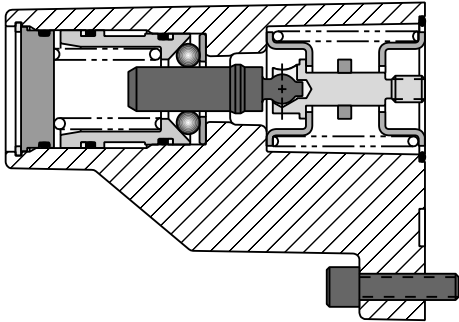

4 Position Detent Assembly Code...B5

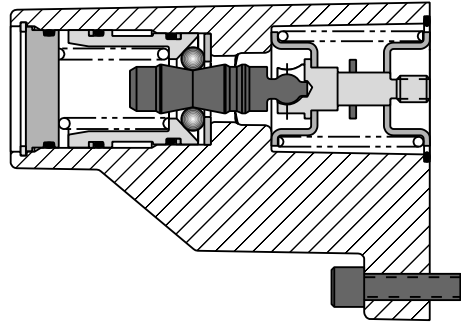

Port Options

Code...E
1601-566-021

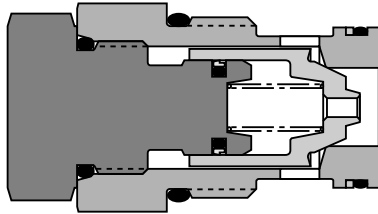

Code...P()
1695-430-001

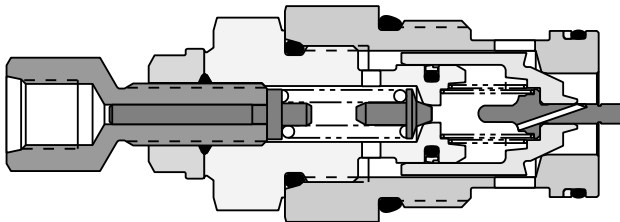

Code...G()
1697-430-002 (300...1400 psi)
1697-430-001 (1450...4500 psi)

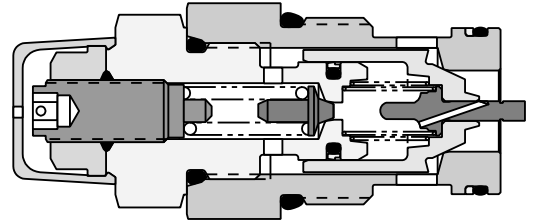

Code...Q
19-76202-019

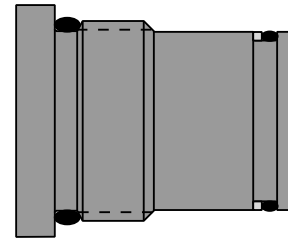

Pressure Compensator Control Options

Code...B()
1602-566-026

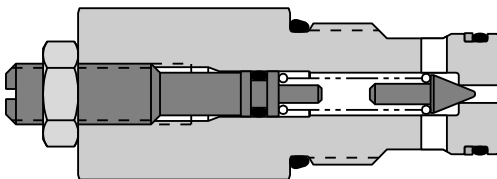

Code...C
1602-566-045

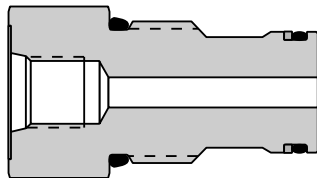

Shuttles

Double Acting Primary Shuttle
1604-566-002

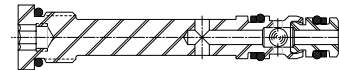

Orificed Primary Shuttle
1604-566-004

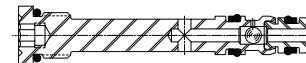

Single Acting "A" Only Shuttle
1604-566-009

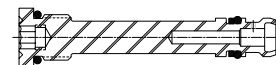

Single Acting "B" Only Shuttle
1604-566-006

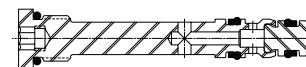

End Covers

Code...L

Standard End Cover

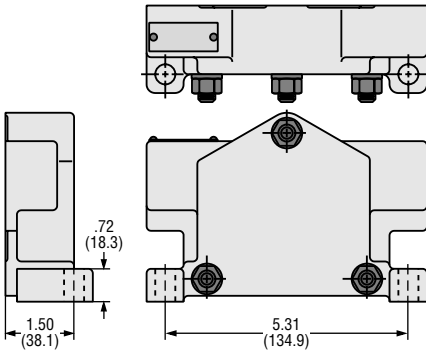

Code... Q

End cover with pressure reducing valve integral for Electro-Hydraulic controlled sections. (Includes drain port T2)

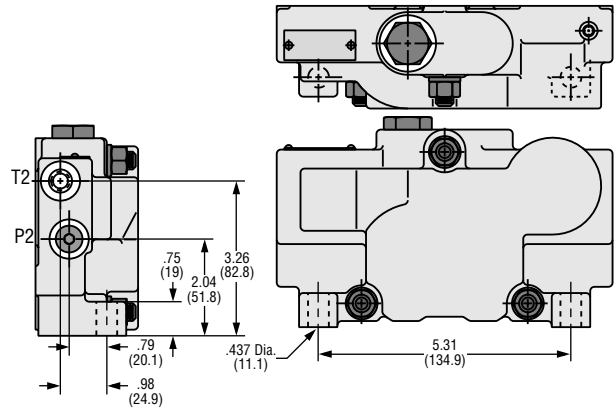

Code...R

End cover w/ external supply pressure port for Electro-Hydraulic controlled sections. (Includes pressure port P2 and drain port T2)

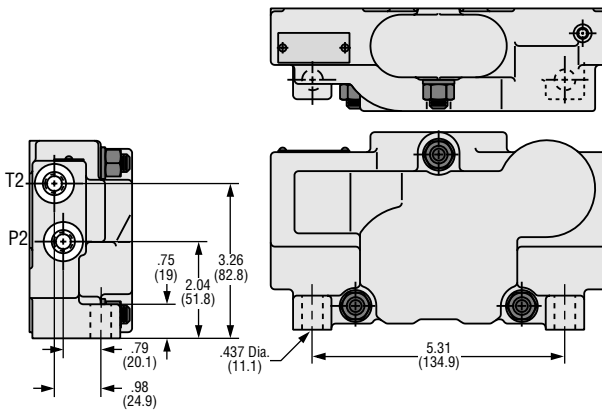

Code...S

End cover w/ pressure reducing valve integral for pilot controller supply. Not to be used with Electro-Hydraulic sections. (Includes pressure port P2 and drain port T2)

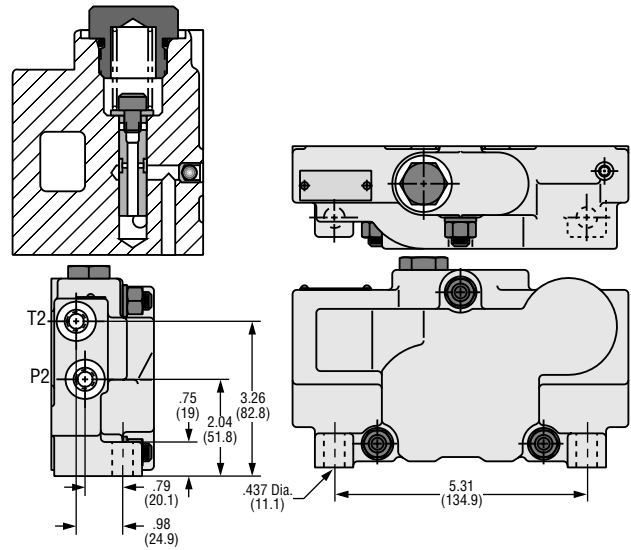

To Add Ports P, T, or LS to End Covers, Add Catalog Code (PTL) to End Cover Codes...L, Q, R, or S.

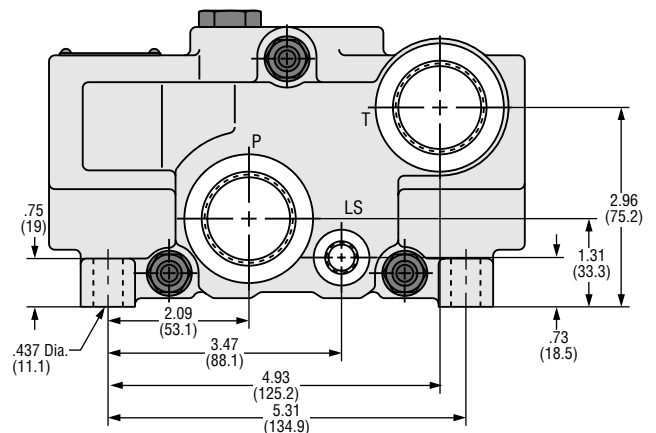
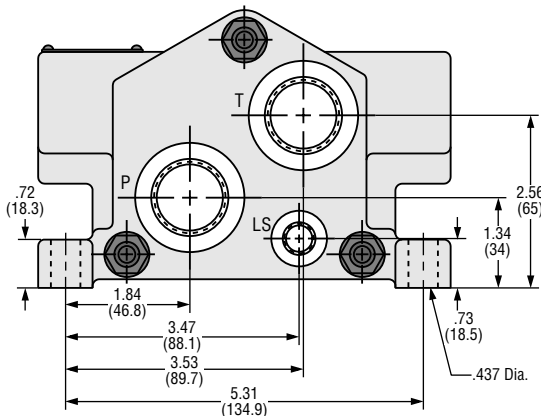

Kit Numbers

Closed Center Tie Bolt Kits

Including shims, o-rings, tie-bolts, nuts, and flat washers.	
1602-635-023	1 section
1602-635-020	2 section
1602-635-021	3 section
1602-635-022	4 section
1602-635-033	5 section
1602-635-034	6 section
1602-635-035	7 section
1602-635-036	8 section

Open Center Tie Bolt Kits

Including shims, o-rings, tie-bolts, nuts, and flat washers.	
1602-635-037	1 section
1602-635-038	2 section
1602-635-039	3 section
1602-635-040	4 section
1602-635-041	5 section
1602-635-042	6 section
1602-635-043	7 section
1602-635-044	8 section

Service Kits

1602-635-031	Face seal kit (seal between sections including shims)
1602-635-061	Seal kit electrical section pilot face seals
1602-635-086	Seal kit electrical section pilot face seals
1602-635-078	Priority inlet seal kit
1602-635-001	Dust boot kit
1601-635-040	MP18 & 22 handle & dust boot kit
1604-566-002	Standard primary shuttle double acting
1604-566-004	Orificed primary shuttle double acting
1604-566-006	Single acting shuttle "B"
1604-566-008	Single acting orificed shuttle "B"
1604-566-009	Single acting shuttle "A"
1604-566-011	Single acting orificed shuttle "A"
1602-566-022	Relief cartridge unloading and priority inlet
1604-635-001	Secondary shuttle kit, with ball
1697-430-002	Combination pilot relief/anti-cavitation port option (300-1400 psi)
1697-430-001	Combination pilot relief/anti-cavitation port option (1450-3625 psi)
1601-566-021	Anti-cavitation check valve
19-76202-019	Port option plug
1697-635-001	Seal kit port option
1602-635-094	Open center inlet back pressure check kit
1602-635-116	Mating Solenoid connector Kit - Cannon Connector "C2"
1602-635-117	Mating Solenoid connector Kit - Junior Rimer (AMP) "C4"

Operation Mechanical Detent Kits

1602-635-071	"B" detent kit
1602-635-072	"B1" detent kit
1602-635-073	"B2" detent kit
1602-635-074	"B3" detent kit
1602-635-075	"B4" detent kit
1602-635-068	"A" standard spring centered kit
1602-635-096	Manual override kit-option "L2" & "M2" without solenoid
1602-635-097	Manual override kit-option "H2"

QCC LLC
7301 W. Wilson Avenue,
Harwood Heights, IL 60706
708-887-5400
www.qccorp.com
www.qcc.parts

© 2021 QCC LLC

All rights reserved. Neither this document, nor any part of it, may be reproduced, duplicated, circulated or disseminated, whether by copy, electronic format or any other means, without the prior consent and authorization of QCC LLC.

The data and illustrations in this brochure/data sheet are intended only to describe or depict the products. No representation or warranty, either express or implied, relating to merchantability or fitness for intended use, is given or intended by virtue of the information contained in this brochure/data sheet. The information contained in this brochure/data sheet in no way relieves the user of its obligation to insure the proper use of the products for a specific use or application. All products contained in this brochure/data sheet are subject to normal wear and tear from usage.

Subject to change.