

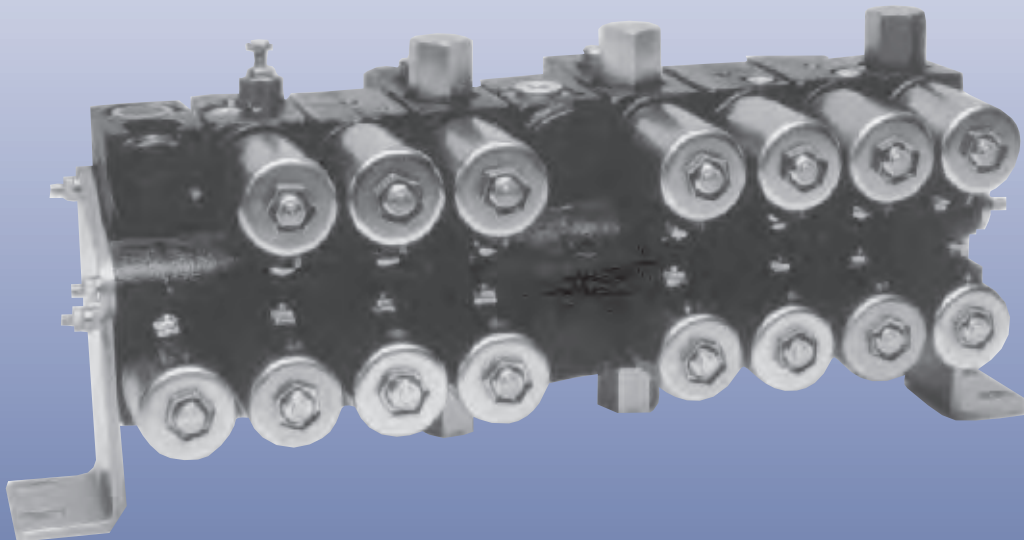

---

# ZMC and ZMV

---



---

## Electrohydraulic Valves

---

## Technical Information

---

---

**General Description**

ZMC stack valves and ZMV proportional valves can be applied with pumps and various actuators to transfer and control hydraulic power.

**ZMC valves** are solenoid-operated stack valves used to control the direction of hydraulic fluid flow to motors, cylinders, and other remote actuators.

ZMC valves use a unique through-tube design to transfer fluid from module to module in the stack. The solenoid pilot valves are a reliable three piece design. Solenoids are water resistant with several terminations and voltages available.

The solenoid-operated pilot valves supply pilot flow to the larger directional control spools and poppets. This allows for full pressure to shift these spools when the pilot valve is energized.

**ZMV valves** are solenoid-operated proportional flow controls used to control the amount of flow to a hydraulic actuator.

The ZMV proportional valves are stand-alone designs that are controlled by a pulse width modulated (PWM) signal. Electronic controllers are also available to satisfy system requirements.

- **ZMV and ZMC valves - Solutions for Low Flow Applications**
- **Complete Line of Directional Control Valves**
- **Optional Spools to Satisfy Diverse Applications**
- **Proven Reliability & Performance**
- **Modular Product Design**

**Introduction ..... 2**

    General Description ..... 2

    Product Features ..... 4

    Technical Specifications ..... 5

**ZMC Module Specifications ..... 6**

    ZMC - UVO Module: 2-Position/2-Way Normally Open Unload Valve ..... 7

    ZMC - UVC Module: 2-Position/2-Way Normally Closed Unload Valve ..... 8

    ZMC - UVF Module: 2-Position/2-Way Field Convertible Unload Valve ..... 9

    ZMC - URO Module: 2-Position/2-Way Normally Open Unload Valve with Integral Relief ..... 10

    ZMC - URF Module: 2-Position/2-Way Field Convertible Unload Valve with Integral Relief ..... 11

    ZMC - PRV Module: Pressure Reducing Valve ..... 12

    ZMC - PFD Module: Priority Flow Dividing Valve ..... 13

    ZMC - DPV Module: 3-Position/3-Way Demand Priority Valve ..... 14

    ZMC - SOV Module: 2-Position/2-Way Pilot-Operated Poppet Valve ..... 15

    ZMC - 240 Module: 2-Position/4-Way Criss-Cross Pilot-Operated Spool Valve ..... 16

    ZMC - 24C Module: 2-Position/4-Way Closed Center Pilot-Operated Spool Valve ..... 17

    ZMC - 340 Module: 3-Position/4-Way Figure Four Pilot-Operated Spool Valve ..... 18

    ZMC - 34C Module: 3-Position/4-Way Closed Center Pilot-Operated Spool Valve ..... 19

    ZMC - 34X Module: 3-Position/4-Way Figure Four Pilot-Operated Spool Valve with P-O Checks ..... 20

    ZMC - 34Y Module: 3-Position/4-Way Closed Center Pilot-Operated Spool Valve with P-O Checks ..... 21

    ZMC - PPV Module: 3-Position/3-Way Normally Closed Pilot-Operated Poppet Valve ..... 22

    ZMC - LFS Module: Standard Low Flow Valve ..... 23

    ZMC - LFH Module: High Pressure Low Flow Valve ..... 24

**ZMV Module Specifications ..... 25**

    ZMV-21O: Open Center Proportional Flow Control Valve ..... 26

    ZMV-21P: Open Center Proportional Flow Control Valve with Power Beyond ..... 27

    ZMV-21C: Closed Center Proportional Flow Control Valve ..... 28

    ZMV-21L: Closed Center Load-Sensing Proportional Flow Control Valve ..... 29

**Configuration Options ..... 30**

    Solenoids ..... 30

    Control Device Options ..... 33

        SCA-35: Single Channel Amplifier ..... 33

        Electronic Control Handle: MCH41CL2287 ..... 34

    Orifice Plugs / Plates ..... 35

    Required Assembly Hardware ..... 36

        Through Tubes / Plug Tubes ..... 36

        Stacking Configurations ..... 37

        Stacking Kits ..... 38

        Module Identification ..... 41

**Outline Drawings ..... 42**

## Product Features

### A Complete Family

- Wide Range of Options
- System Flexibility - Normally Open, Normally Closed, and Field Convertible Valve Assemblies
- Standard Housing and Mounting Patterns for Stacking Any Module
- Pressure Controls for System Protection
- Pilot-Operated Checks for Load Holding

### Performance

- Pressure to 210 bar (3000 psi)
- Flows to 38 l/min (10 gpm)
- Fast Response Times
- Low Leakage Spools
- Low Pressure Drop
- Pilot Operation

### World Product

- Sold Worldwide
- Mobile and Stationary Markets

### Proven Technology

- Unique Product Features
- Unique Assembly and Testing Methods Increases Reliability
- Stack Design Lowers Installation Cost
- Electrohydraulic Proportional Valves For Infinitely Variable Flow
- Custom Module Designs for Unique Applications

### Reliability / Durability

- Long Service Life
- Continuous Duty Solenoids

## Technical Specifications

### Design

Stackable and stand alone two-stage, pilot-operated valves in gray iron housings with hardened steel spools.

### Mounting Configuration

Foot or plate mountings available for horizontal or vertical configuration

### Installation Position

The valves may be mounted in any orientation.

### Electrical Connections

Several terminations and voltages to choose from (see page 32).

### Port Connections

All ports are standard SAE O-ring boss ports. See Order Code (p. 6) or Outline Drawings (p. 45) for specific port sizes.

### Stack Size

One to eight valve modules per stack.

### Corrosion Resistance

Iron housing are painted black. Other external parts are zinc plated.

## Technical Data:

	ZMC Stack Valves	ZMV Proportional Valves
Maximum Pressure Rating	210 bar 3000 psi	210 bar 3000 psi
Flow Rating	38 l/min 10 gpm	38 l/min 10 gpm
Minimum Working Pressure	20 bar 300 psi	Not Applicable
Response Time	0.010 to 0.75 sec	Not Applicable
Weight per Module	2.6 to 4.2 kg 5.7 to 9.2 lb	4.2 kg 9.2 lb
Spool Leakage (at 210 bar [3000 psi])	164 cm <sup>3</sup> /min 10 in <sup>3</sup> /min	2.0 cm <sup>3</sup> /min 0.5 in <sup>3</sup> /min
Poppet Leakage	2 drops/min	Not Applicable
Electrical Current Range for Continuous Duty Coils	0.83 to 1.5 Amp (±20% Voltage Tolerance)	0 to 1.0 Amp (±20% Voltage Tolerance)
Temperature Range: Buna-N Seals Viton Seals	-35°/120°C [-30°/250°F] -25°/205°C [-15°/400°F]	-35°/120°C [-30°/250°F] -25°/205°C [-15°/400°F]
Hydraulic Fluid	Any general hydraulic fluid	Any general hydraulic fluid
Filtration	10 micron nominal	10 micron nominal

**ZMC - LFH Module:  
 High Pressure Low Flow Valve**

**Description**

The LFH module is a three-way, three-position solenoid-operated poppet valve. It is commonly used as directional control for single-acting cylinders with low flow requirements. It has a higher cracking pressure for use with higher pressure flows. This module also contains pressure protection for the work port.

**Operation**

The direct-acting poppets are spring-biased closed. Energizing the solenoid will open the poppets and allow flow to or from the work port.

**Specifications**

<b>Weight</b>	3.1 kg	6.9 lb
<b>Ports: Work</b>	#4 SAE 7/16-20	
<b>Response Time (sec)</b>		
<b>Coil Duty:</b>	Intermittent	Continuous
<b>Raise</b>	.15	N/A
<b>Lower</b>	.75	N/A

**LFH Cracking Pressure Curve**

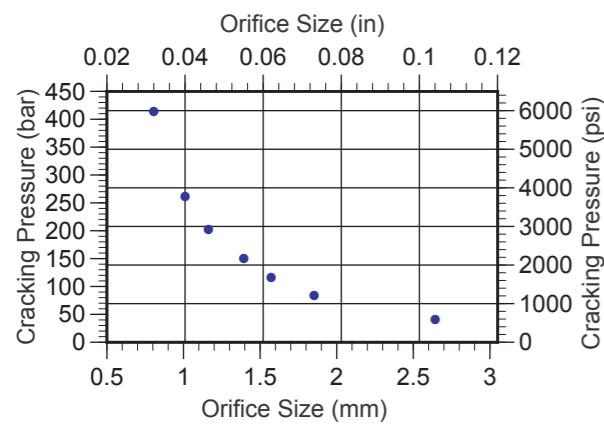

**LFH Pressure Drop Curve**

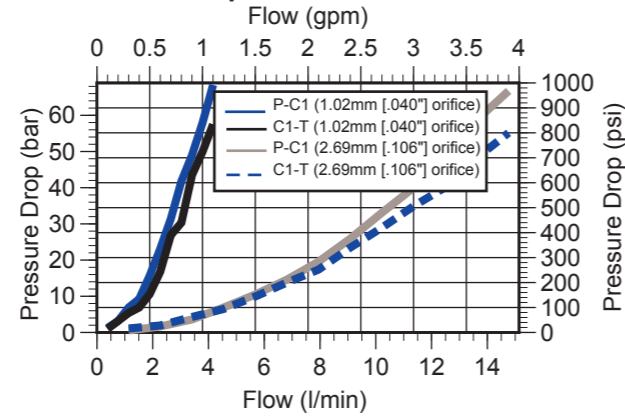

**LFH Schematic**

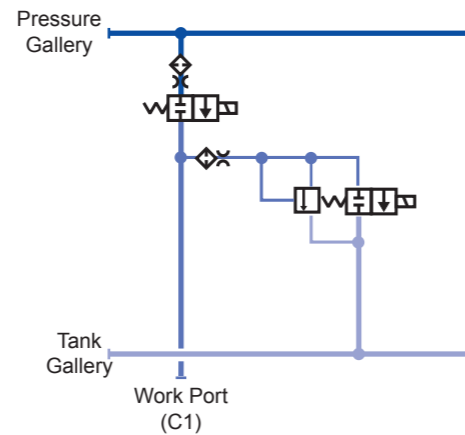

**LFH Cut-away**

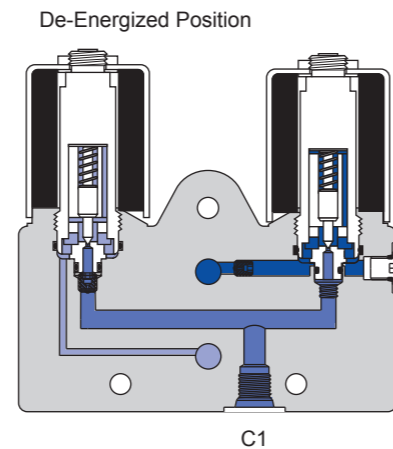

**Description**

ZMV modules are electronic proportional valve assemblies used to control flow to a motor or other type of actuator. They include pressure compensation to accurately control flow regardless of load pressure. A manually adjustable override is available to bypass the proportional electrical valve. ZMV modules are stand alone units and are not stackable.

ZMV modules are available in open center (21O and 21P) and closed center (21C and 21L) valve configurations. The open center module can include a Power Beyond port to channel excess flow to another function (21P). The closed center module can come with load sensing capability (21L).

Typical applications include variable motor speed circuits on combines, salt spreader applications on trucks, and hydraulic motor conveyers.

**Operation**

The module's pilot valve is spring-biased normally closed. When a pulse width modulated (PWM) signal of 35 to 100 Hz is applied to the solenoid, the valve will open proportionally to the current. The compensating spool maintains a constant pressure drop across the pilot valve (or manual valve) and therefore pressure compensates the priority flow.

A potentiometer and electronic driver on page 35 or a joystick control on page 36 may be used to supply the valve input signal.

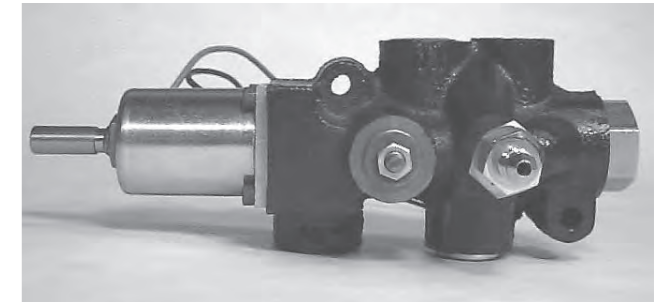

### ZMV-210: Open Center Proportional Flow Control Valve

#### Description

The ZMV 210 valve is designed for open center systems (e.g. fixed displacement pumps). Controlled flow is pressure compensated. Excess flow is always bypassed to tank.

#### Specifications

<b>Weight</b>		4.2 kg	9.2 lb
<b>Ports:</b>	<b>Pressure</b>	#10 SAE 7/8-14	
	<b>Controlled</b>	#10 SAE 7/8-14	
	<b>Tank</b>	#10 SAE 7/8-14	
<b>PWM Frequency Range</b>		35 - 100 Hz	
<b>PWM Current Range</b>		0 - 1.2 Amps	
<b>Flow:</b>	<b>Pressure</b>	76 l/min	20 gpm
	<b>Controlled</b>	38 l/min	10 gpm

210 Schematic

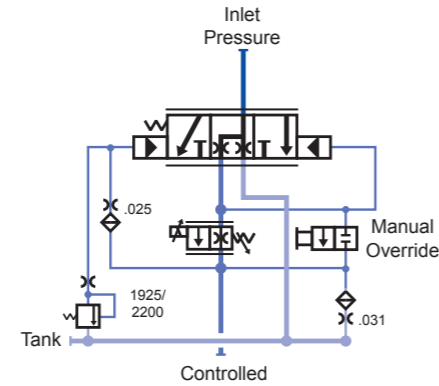

210 Cut-away

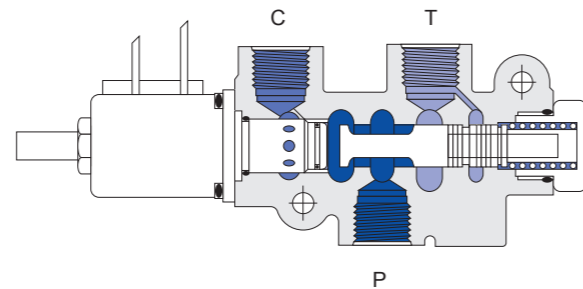

210 Pressure Drop vs Flow Curve

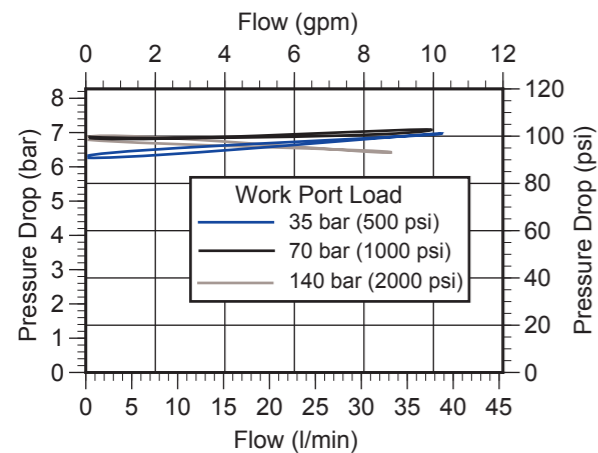

210 Flow vs Current Hysteresis Curve

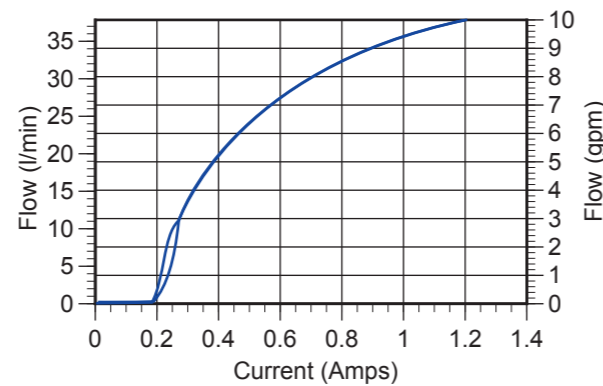

### ZMV-21P: Open Center Proportional Flow Control Valve with Power Beyond

#### Description

The ZMV-21P valve is designed for open center systems (fixed displacement pumps). Controlled flow is pressure compensated. A bypass function unloads excess flow to the Power Beyond port. This flow is not pressure compensated.

#### Specifications

<b>Weight</b>		4.2 kg	9.2 lb
<b>Ports:</b>	<b>Pressure</b>	#10 SAE 7/8-14	
	<b>Controlled</b>	#10 SAE 7/8-14	
	<b>Power Beyond</b>	#10 SAE 7/8-14	
	<b>Tank</b>	#4 SAE 7/16-20	
<b>PWM Frequency Range</b>		35 - 100 Hz	
<b>PWM Current Range</b>		0 - 1.2 Amps	
<b>Flow:</b>	<b>Pressure</b>	76 l/min	20 gpm
	<b>Controlled</b>	38 l/min	10 gpm

21P Schematic

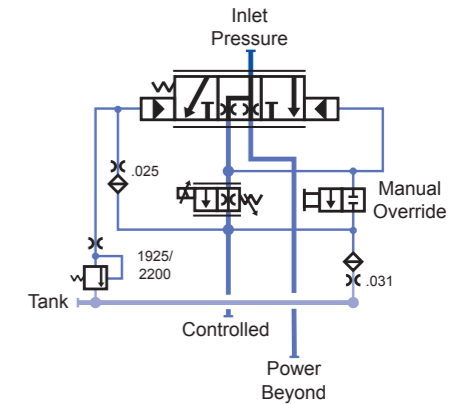

21P Cut-away

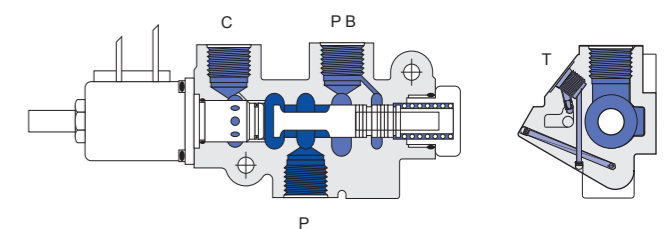

21P Pressure Drop vs Flow Curve

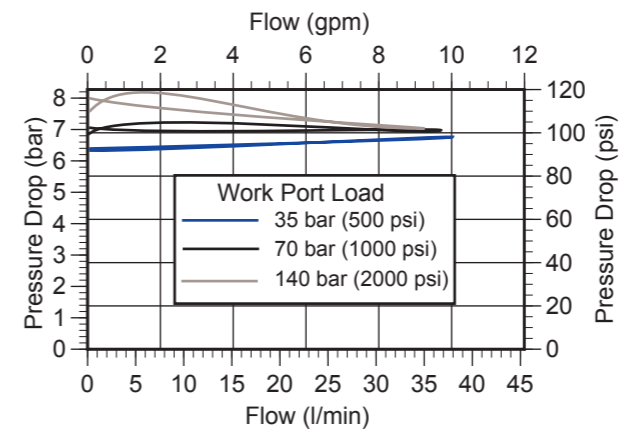

21P Flow vs Current Hysteresis Curve

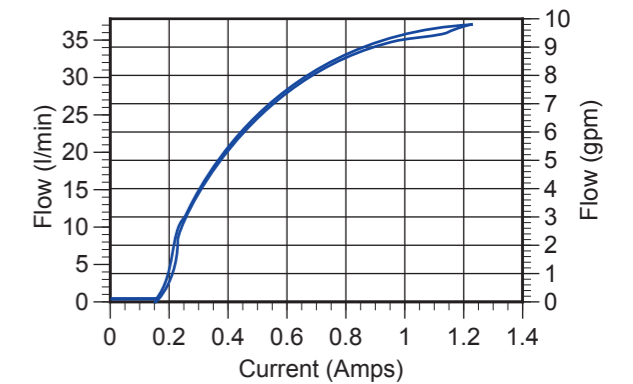

**ZMV-21C: Closed Center Proportional Flow Control Valve**

**Description**

The ZMV-21C valve is designed for closed center systems (variable displacement pumps).

**Specifications**

<b>Weight</b>	4.2 kg	9.2 lb
<b>Ports:</b>	<b>Pressure</b>	#10 SAE 7/8-14
	<b>Controlled</b>	#10 SAE 7/8-14
	<b>Tank</b>	#6 SAE 9/16-18
<b>PWM Frequency Range</b>	35 - 100 Hz	
<b>PWM Current Range</b>	0 - 1.2 Amps	
<b>Flow:</b>	<b>Pressure</b>	76 l/min 20 gpm
	<b>Controlled</b>	38 l/min 10 gpm

**21C Schematic**

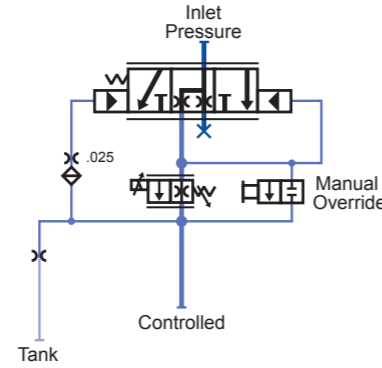

**21C Cut-away**

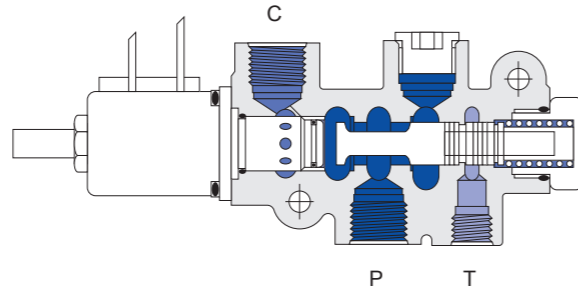

**21C Pressure Drop vs Flow Curve**

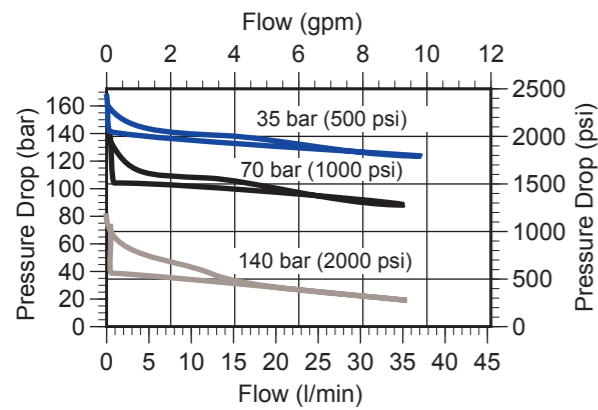

**21C Flow vs Current Hysteresis Curve**

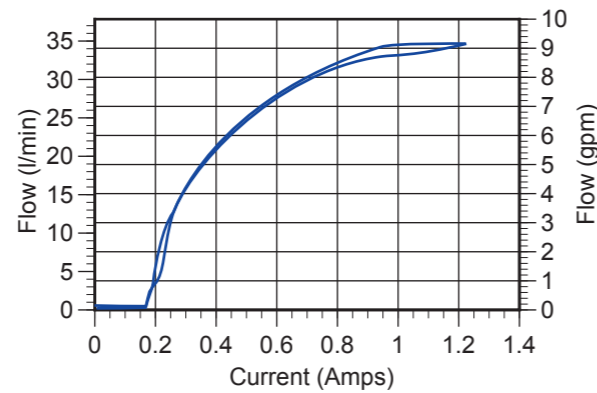

**ZMV-21L: Closed Center Load-Sensing Proportional Flow Control Valve**

**Description**

The ZMV-21L valve is designed for closed center load sense systems (variable displacement pumps).

**Specifications**

<b>Weight</b>	4.2 kg	9.2 lb
<b>Ports:</b>	<b>Pressure</b>	#10 SAE 7/8-14
	<b>Controlled</b>	#10 SAE 7/8-14
	<b>Load Sense</b>	#6 SAE 9/16-18
	<b>Tank</b>	#6 SAE 9/16-18
<b>PWM Frequency Range</b>	35 - 100 Hz	
<b>PWM Current Range</b>	0 - 1.2 Amps	
<b>Flow:</b>	<b>Pressure</b>	76 l/min 20 gpm
	<b>Controlled</b>	38 l/min 10 gpm

**21L Schematic**

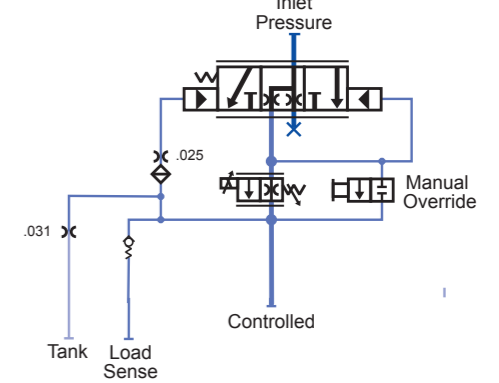

**21L Cut-away**

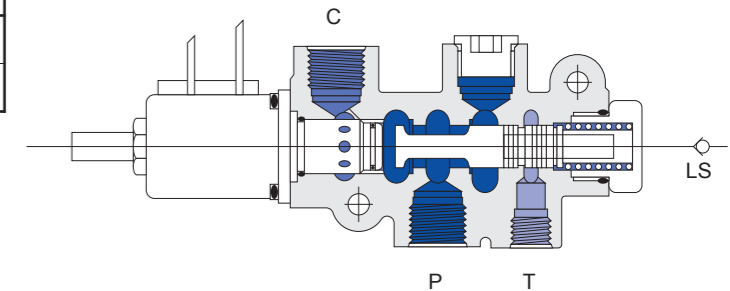

**21L Pressure Drop vs Flow Curve**

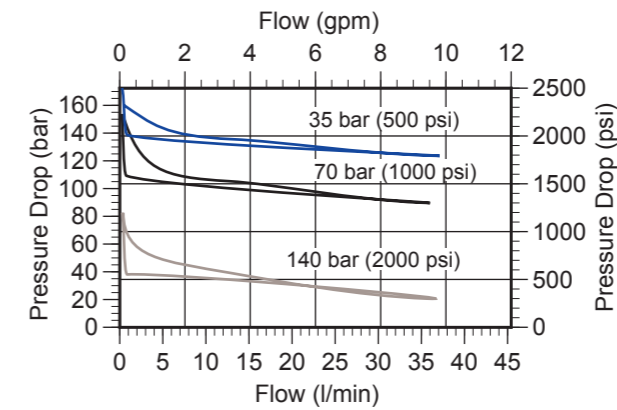

**21L Flow vs Current Hysteresis Curve**

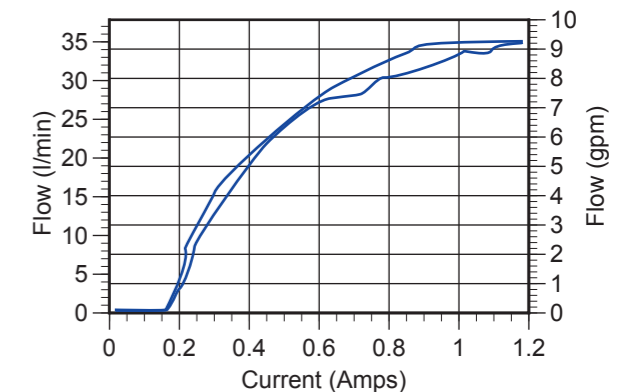

## Solenoids

### General Description

ZMC and ZMV valves utilize the same solenoid design. This two piece design consists of an encapsulated coil and a metal enclosure.

Several terminations, voltages, and diodes are available. Intermittent solenoids are used to improve response time. Consult duty cycle ratings when using intermittent duty solenoids.

### Specifications

#### Resistance and Wattage:

Continuous duty coil at 20°C (70°F):

Coil Duty:	Continuous		Intermittent	
	Duty Voltage (VDC)	Resistance (Ω)	Power (W)	Resistance (Ω)
6	3.6	10	--	--
12	14.5	10	3.6	40
24	57.2	10	14.5	40

#### Lead Wires:

20 gauge, 18" long

#### Encapsulating Material:

Cyglass

#### Arc Suppression Diode (Optional):

IN4004

#### Coil Nut Torque:

ZMC Valves	7.3 Nm	65 in•lbf
ZMV Valves	2.8 Nm	25 in•lbf

110VAC solenoids are internally rectified. They are rated for reverse voltage spikes of 400 volts maximum.

Standard solenoids are not hermetically sealed. Contact QCC regarding applications requiring waterproof solenoids.

#### Duty Rating:

Rated voltage at 50°C (120°F):

Continuous Duty	±20%
Intermittent Duty	±20%

#### Temperature Range:

Class H, -40°C to 82°C (-40°F to 180°F)

### Solenoid Temperature Rise Curve

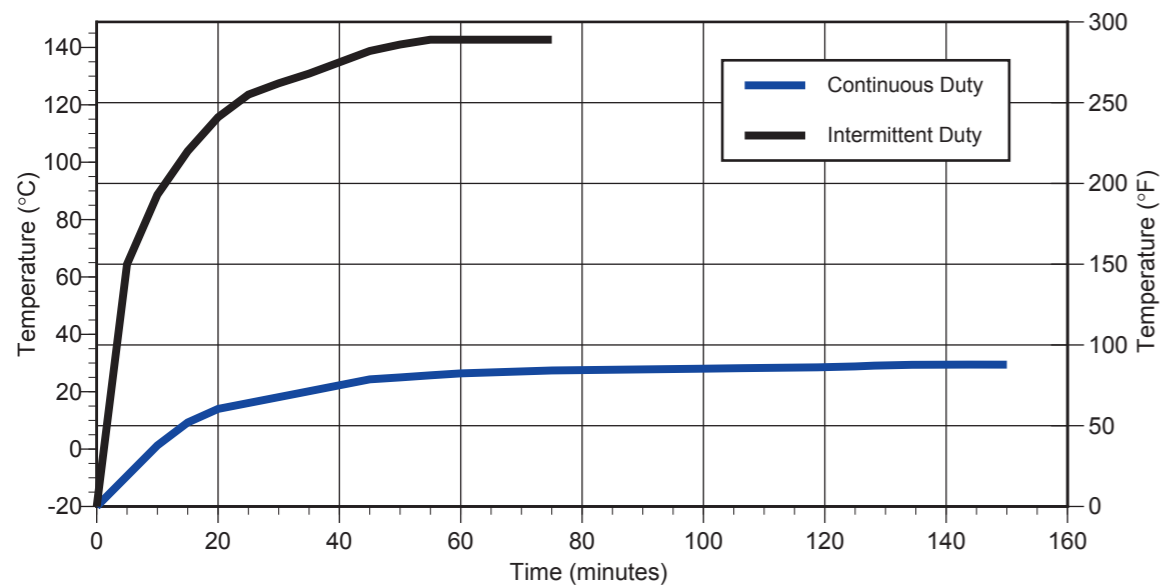

## Solenoid Outline Drawings

A variety of solenoids are available to choose from. See the Order Code on page 6 for available voltages. (Mating connectors are not included with solenoid.)

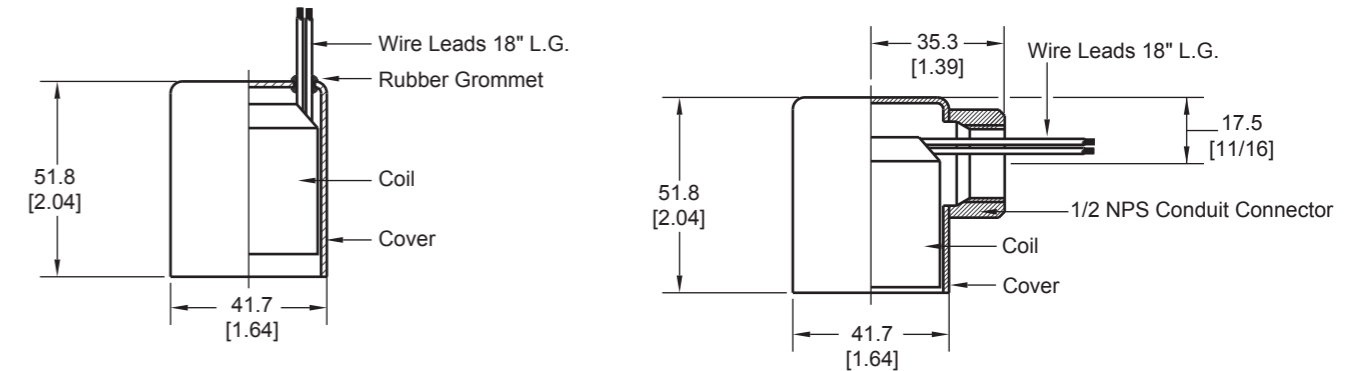

Grommet / Wire Leads

Conduit / Wire Leads

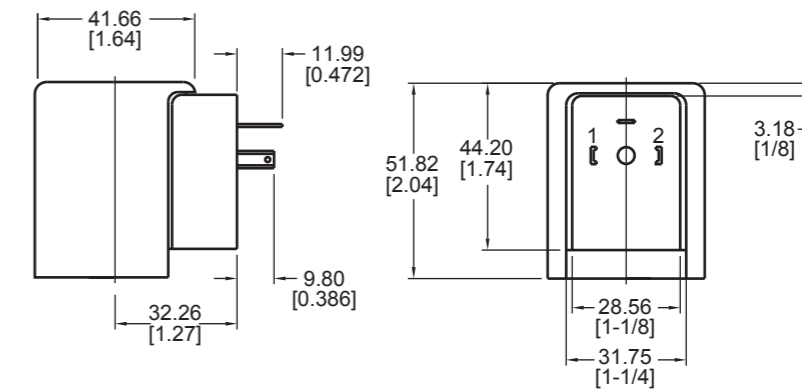

DIN 43650

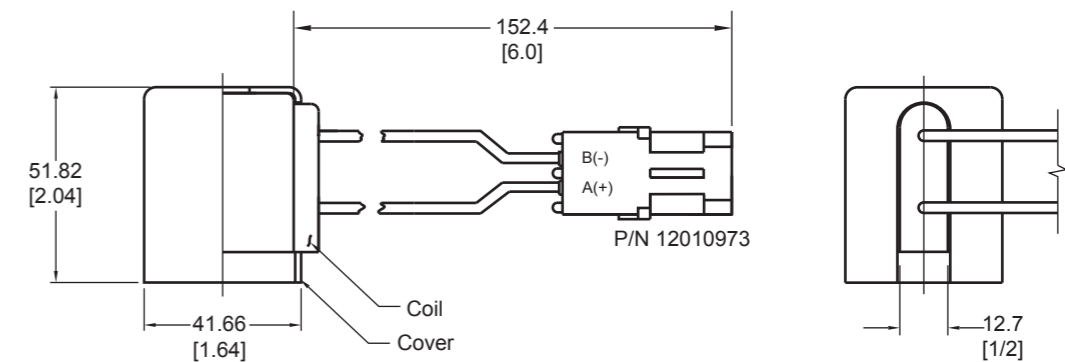

Weather Pack 12010973

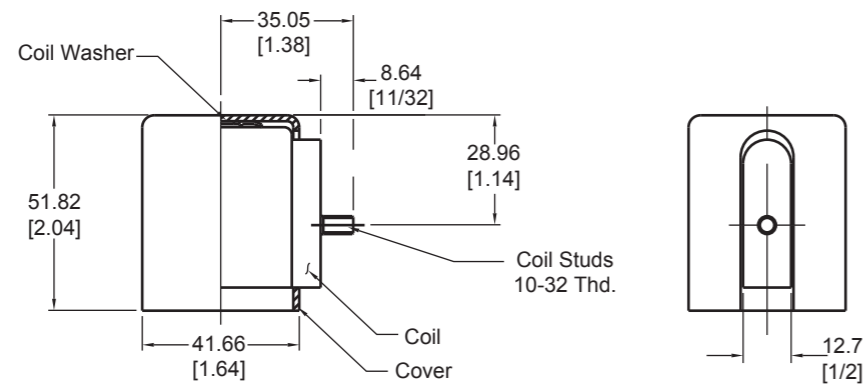

Single Stud

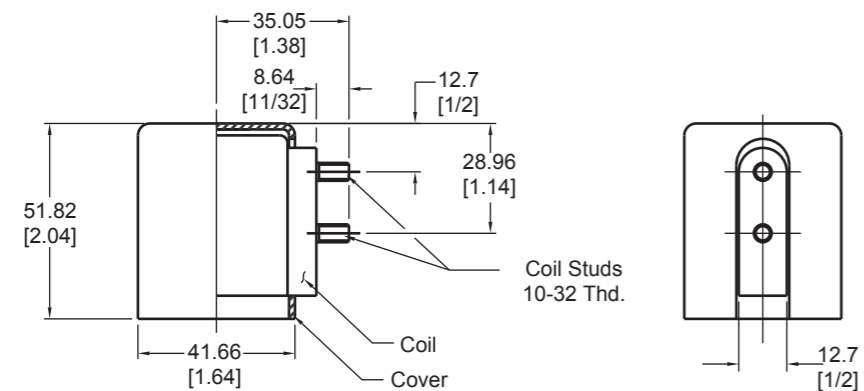

Double Stud

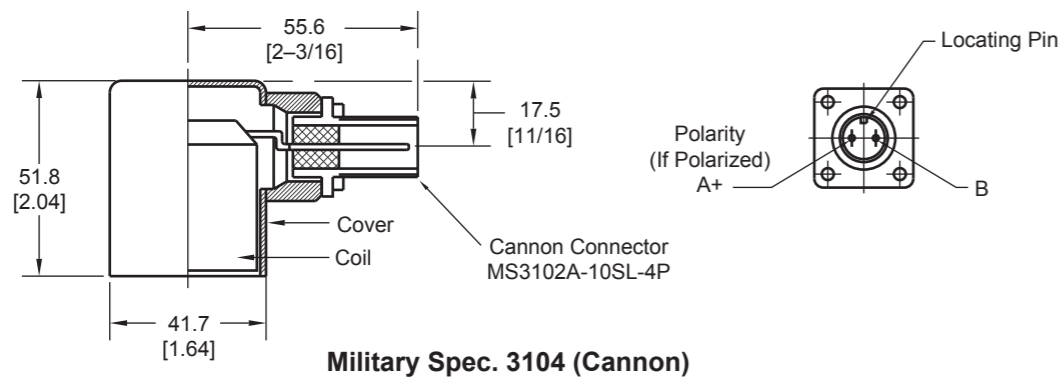

Military Spec. 3104 (Cannon)

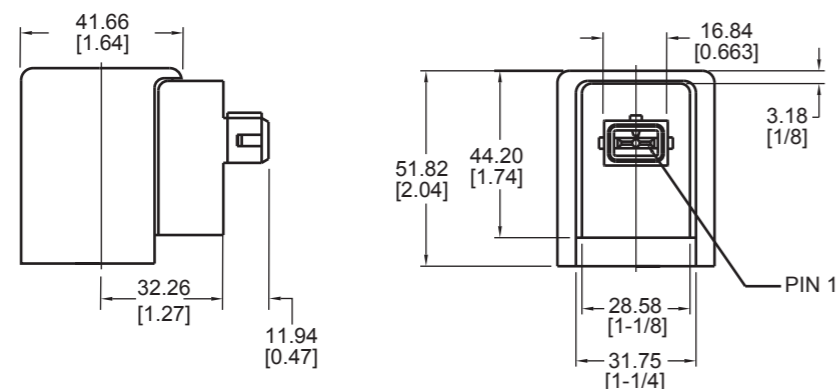

Amp Junior

## Control Device Options

### SCA-35: Single Channel Amplifier

#### Description

The SCA-35 single channel amplifier is designed to optimize the performance of ZMV series pressure-compensated flow control valves in handling flows from 4 to 38 l/min (1 to 10 gpm).

The SCA-35's current feedback provides low hysteresis by compensating for fluctuations in input voltage and solenoid resistance. Output overload and arc suppression diode protection is included in the SCA-35. However, arc suppression is also recommended for the valve's coil.

The SCA-35 is fully encapsulated for protection against humidity, vibration, and shock.

#### Operation

The control signal to the driver is generated by a potentiometer or an analog signal. The amplifier provides no output until the control input is greater than 1% of the internal reference voltage (+5 VDC).

A 2Ω, 2.25 watt resistor with 29% of travel is available

from QCC (P/N K10197, Knob P/NK04860).

This system allows the operator to turn off the valve without switching input power. The addition of optional resistors allows the driver to maximize the resolution of the set point potentiometer. These may be fixed resistors or a variable potentiometer.

#### Specifications

Supply Voltage	9.6 - 16.0 VDC
Operating Frequency	35 Hz
Maximum Continuous Output Current	1.1 Amp
Input signal	>2 kΩ, 0-5 VDC, >1 Amp
Connections <small>(Mating Connectors must be ordered separately.)</small>	Packard Weatherpack 6 pin mating connector (P/N 12015799).
Weight	0.26 kg    0.57 lb
Package Dimensions	99 x 54 x 39    3.9 x 2.1 x 1.5 mm                    in
Mounting Orientation	any
Temperature Range	-40 to 85°C    -40 to 185°F

#### Output vs. Input

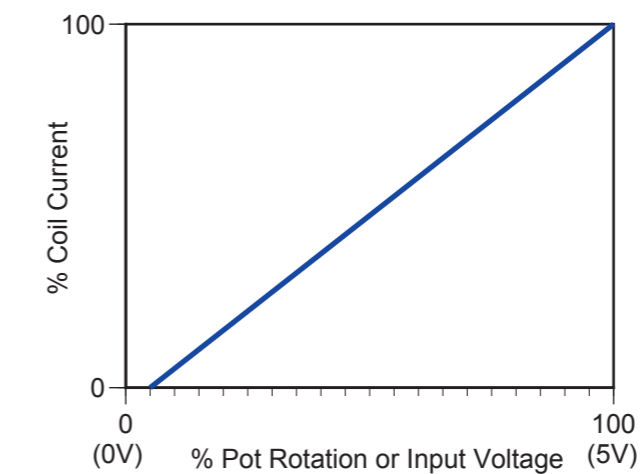

Note: No Output from 0 - .05V

#### Outline Dimensions

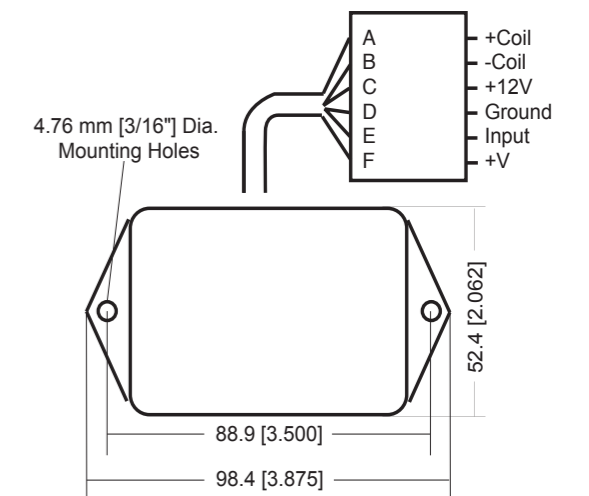



**Electronic Control Handle: MCH41CL2287**

**Description**

This panel mount control handle is designed to operate the ZMV series flow control valves. It is enclosed in a plastic case and includes a non-locking knob and friction-held control.

Combined with any ZMV valve, this driver will provide a complete pressure compensated flow control system to handle 4 to 38 l/min (1 to 10 gpm).

The control handle's current feedback provides repeatability by compensating for fluctuations in input voltage and solenoid resistance. Output overload and arc suppression protection is included in the control handle. However, arc suppression is also recommended for the coil.

**Operation**

The control signal to the driver is generated by a potentiometer located in the control handle. The amplifier provides no output until the control input is greater than 1% of the internal reference voltage (+5 VDC). This allows the operator to turn off the valve without switching input power.

**Specifications**

Supply Voltage	9.6 - 16.0 VDC
Operating Frequency	100 Hz
Maximum Output Current	1.1 Amp
Input signal	> 2 kΩ, 0-5 VDC, > 1 Amp
Connections	Packard Weatherpack 6 pin mating connector (P/N 12015799) <small>Mating connectors are not included.</small>
Weight	0.26 kg 0.57 lb
Temperature Range	-40 - 85°C -40 - 185°F

**Outline Drawings**

For other control handle options consult SAS BLN 95-9049

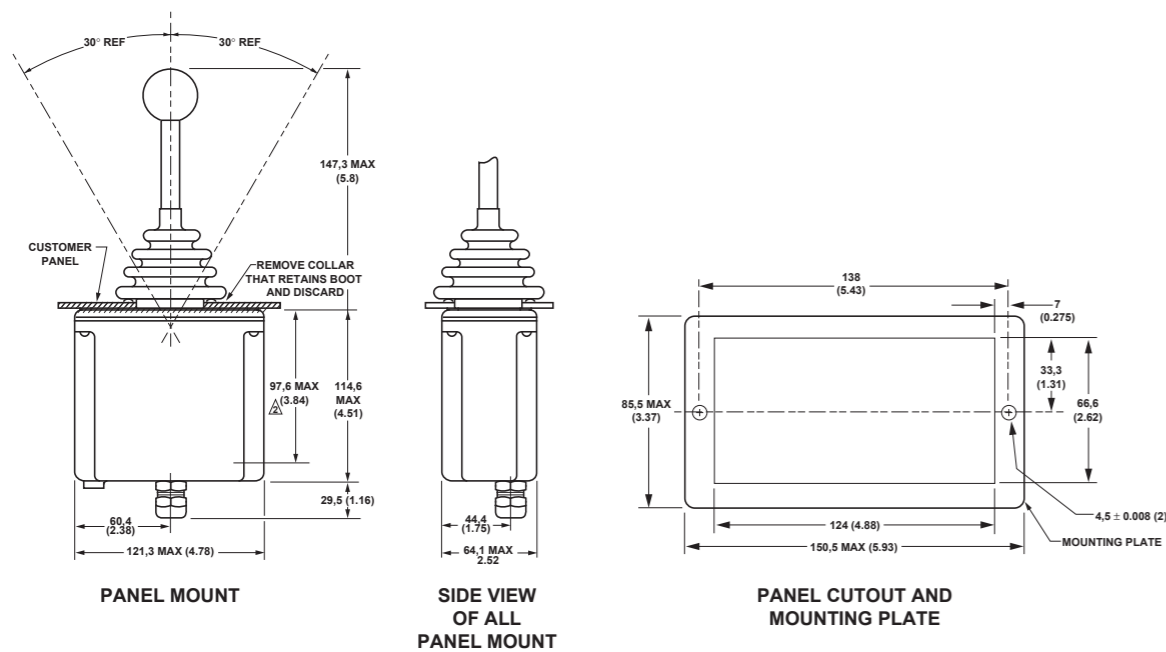

**Orifice Plugs / Plates**

Standard threaded orifice plugs are available to mount in the ZMC-240, 24C, 340, 34C, 34X, and 34Y modules. Orifice plates are also available to place in

the work ports of the above modules. Below are graphs showing the orifice size required based on the flow and pressure drop desired.

**Orifice Size for Specific Flow and Pressure Drop**

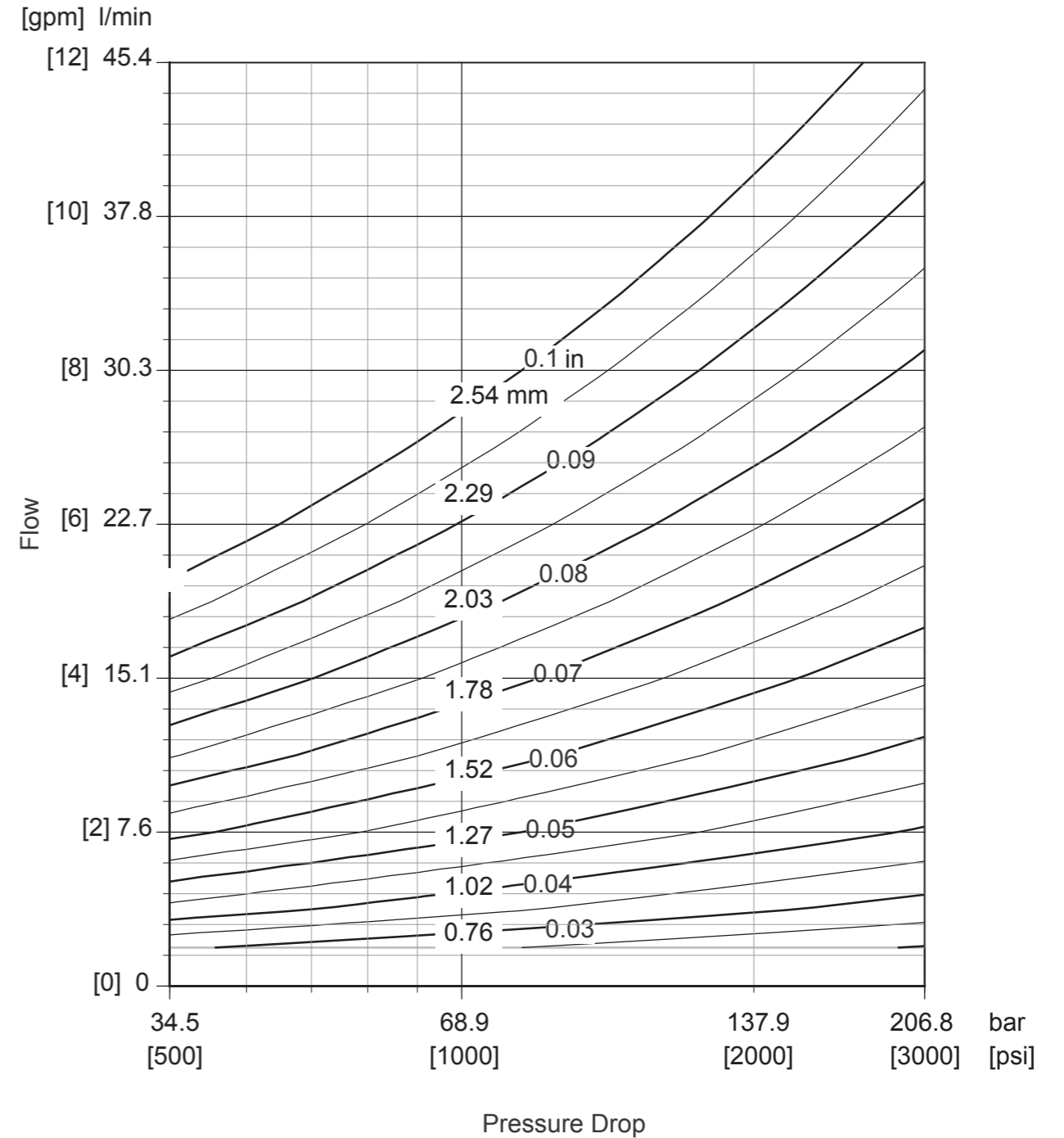

## Required Assembly Hardware

### Through Tubes / Plug Tubes

All ZMC modules utilize common pressure and tank galleries running through the length of the valve stack. Each through tube includes two sets of O-rings and back up rings for elimination of leakage between the modules.

Three tie bolts are used in each ZMC valve stack to join the modules together. The through tubes assist in aligning the modules into the stack. This eliminates the spool binding that occurs due to over torquing the tie bolts or mounting to uneven surfaces.

Plug tubes are used to seal the pressure and tank galleries at the end of the valve stack. To add modules to an assembled valve stack the plug tubes can be removed and replaced by a through tube to accommodate additional modules.

Plug tubes can also be used to isolate a particular module's pressure and/or tank gallery from the rest of the stack.

#### Tube Part Numbers

Plug Tube	Z2819006
Standard Through Tube	Z2812011
Long Through Tube	Z2812012

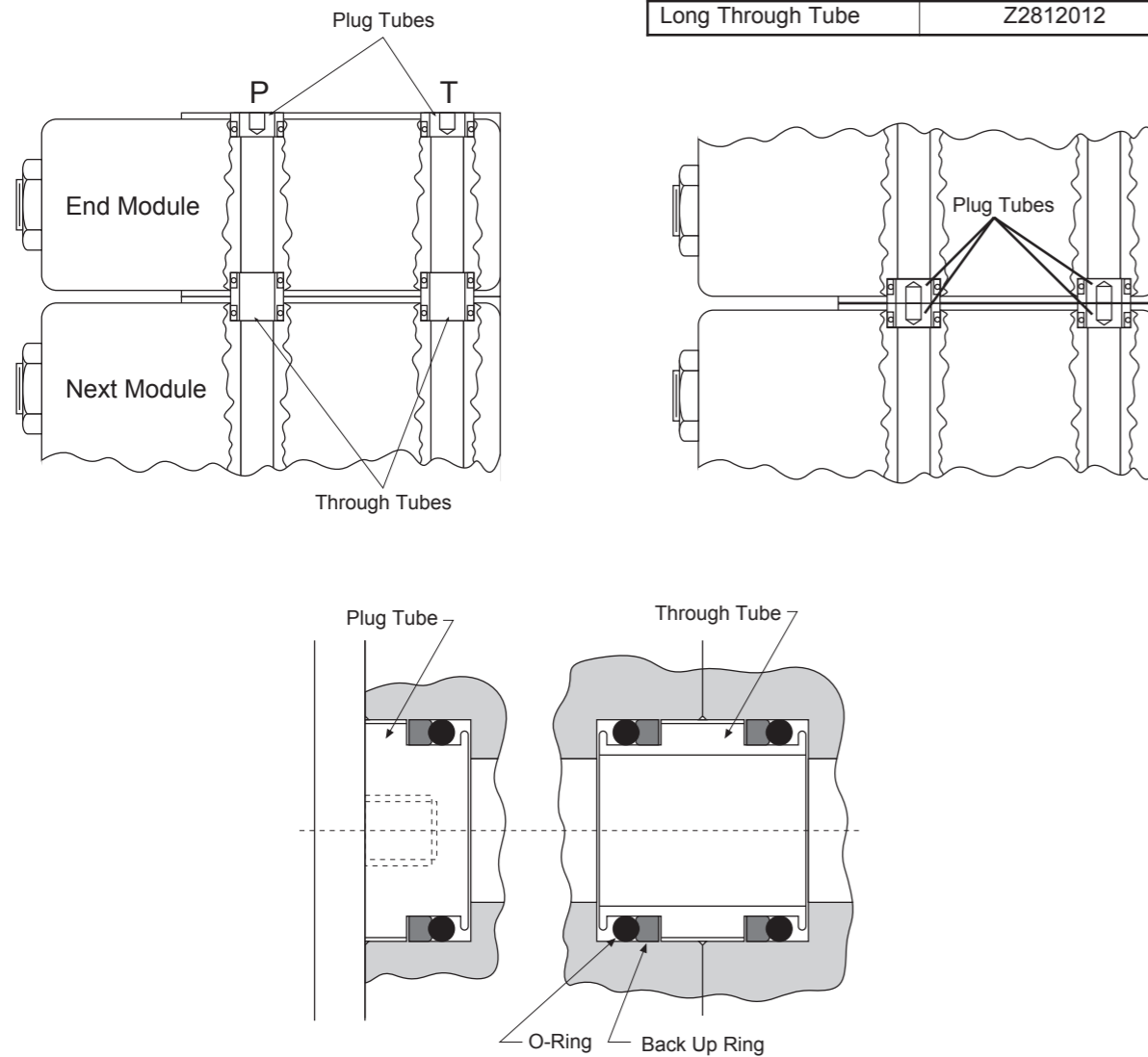

## Stacking Configurations

Valve assemblies can be mounted in any direction, but for clarity a valve stack with "L" brackets is referred to as "**Horizontal**" and a stack without "L" brackets as "**Vertical**" (see figures).

"L" feet mounting brackets and end plates are provided to support the complete stack. The brackets are stamped from steel and zinc plated. Tie bolts are used to fasten the stack together. Pressure and tank connections are made either through the appropriate

end caps or through the Unload modules (UVx, URx). Plug tubes are inserted in the end modules to seal the pressure and tank galleries.

An alternative mounting style is to use the tie bolts to fasten the valve stack to a customer-supplied metal plate.

All ZMC modules can also be utilized as stand alone line mount valves.

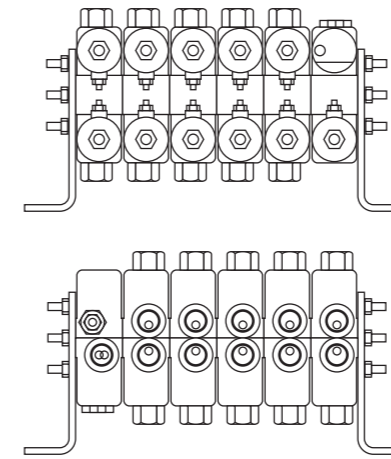

"Horizontal" Stack Assembly

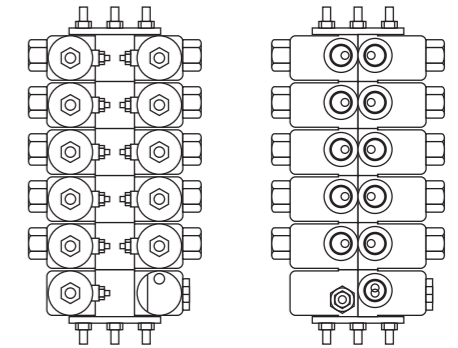

"Vertical" Stack Assembly

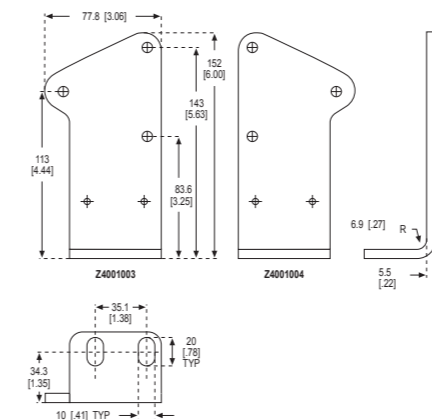

"L" Mounting Bracket

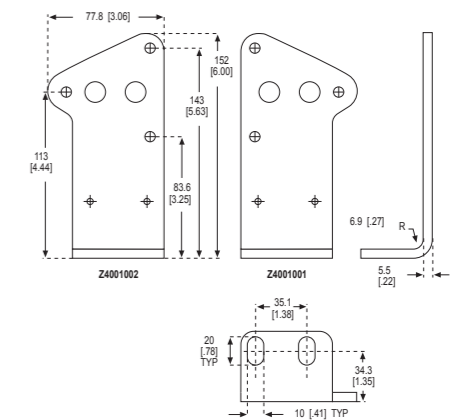

"L" Mounting Bracket with Port Access

**Stacking Kits**

Currently six stacking kit configurations are offered. These are listed in tables on the following pages.

Stack Type	Hardware	Table
Horizontal	Two Mounting Brackets, No End Caps	A
Horizontal	Two Mounting Brackets, One End Cap with Ports Right	B
Horizontal	Two Mounting Brackets, One End Cap with Ports Left	C
Horizontal	Two Mounting Brackets, Two End Caps with Ports	D
Vertical	Two End Plates, One Tapped	E
Vertical	One Tapped End Plate, One End Cap with Ports	F

These stacking kits include all the hardware to assemble up to eight individual valve modules into a single valve stack. "End caps *with ports*" must be ordered separately due to individual port requirements. The standard end cap is P/N Z4001010, this has two SAE-8 ports (see page 45 for others).

For vertical stacks, tapped end plates eliminate the need for nuts and washers at the end of the stack.

The tapped end plates are attached to the stack via the through-bolt.

A stacking kit part number is determined as follows:

1. Decide if a **Horizontal** or **Vertical** configuration (described above) is required.
2. Determine if an end cap *with ports* is required. If no unload module (UVx, URx) is used, an end cap *with ports* must be used. This allows the pressure and tank lines to be connected to the valve stack.
3. Go to the table that corresponds to the configuration required. Under the column indicating the correct number of modules choose the corresponding part number for either a factory-assembled stack or an unassembled stack kit.

Factory assembled stacks will be completely assembled and pressure-tested as a stack. A single "stack" part number will be generated for reordering.

When ordering please supply either the stack part number or all module order codes (page 6) and corresponding stacking kit part numbers.

**Table A: Horizontal Configuration, Two Mounting Brackets, No End Caps**

Number of Modules in Stack		1	2	3	4	5	6	7	8
Factory Assembled Stacking Kit P/N	Z669180001	Z669170002	Z669160003	Z669150004	Z669140005	Z669130006	Z669120007	Z669110008	Z669100009
	Z669110001	Z669100002	Z669090003	Z669080004	Z669070005	Z669060006	Z669050007	Z669040008	Z669030009
Unassembled Stacking Kit P/N	Z669110001	Z669100002	Z669090003	Z669080004	Z669070005	Z669060006	Z669050007	Z669040008	Z669030009
PART NUMBER	DESCRIPTION								
Z2812011	THRU-TUBE	-	2	4	6	8	10	12	14
Z2812012	LONG THRU-TUBE	-	-	-	-	-	-	-	-
Z2819006	PLUG TUBE	4	4	4	4	4	4	4	4
Z8229001	HEX NUT	3	3	6	6	6	6	6	6
Z8230001	LOCKWASHER	6	6	6	6	6	6	6	6
Z4001004	RIGHT BRACKET	1	1	1	1	1	1	1	1
Z4001003	LEFT BRACKET	1	1	1	1	1	1	1	1
TIE-RODS	(in) LENGTH (mm)								
Z8240009	3 76.2	3	-	-	-	-	-	-	-
Z8240016	4-3/4 120.6	-	3	-	-	-	-	-	-
Z8208001	7-1/4 184.2	-	-	3	-	-	-	-	-
Z8208008	9 228.6	-	-	-	3	-	-	-	-
Z8208015	10-3/4 273.0	-	-	-	-	3	-	-	-
Z8208022	12-1/2 317.5	-	-	-	-	-	3	-	-
Z8208029	14-1/4 361.9	-	-	-	-	-	-	3	-
Z8208036	16 406.4	-	-	-	-	-	-	-	3

NUMBER OF PIECES PER KIT

**Table B: Two Mounting Brackets, One End Cap with Ports Right, Horizontal Configuration**

Number of Modules in Stack		1	2	3	4	5	6	7	8
Factory Assembled Stacking Kit P/N	Z669180001	Z669170002	Z669160003	Z669150004	Z669140005	Z669130006	Z669120007	Z669110008	Z669100009
	Z669110001	Z669100002	Z669090003	Z669080004	Z669070005	Z669060006	Z669050007	Z669040008	Z669030009
Unassembled Stacking Kit P/N	Z669110001	Z669100002	Z669090003	Z669080004	Z669070005	Z669060006	Z669050007	Z669040008	Z669030009
PART NUMBER	DESCRIPTION								
Z2812011	THRU-TUBE	-	2	4	6	8	10	12	14
Z2812012	LONG THRU-TUBE	2	2	2	2	2	2	2	2
Z2819006	PLUG TUBE	2	2	2	2	2	2	2	2
Z8229001	HEX NUT	3	3	6	6	6	6	6	6
Z8230001	LOCKWASHER	6	6	6	6	6	6	6	6
Z4001003	LEFT BRACKET	1	1	1	1	1	1	1	1
Z4001001	PORTED RIGHT BRACKET	1	1	1	1	1	1	1	1
TIE-RODS	(in) LENGTH (mm)								
Z8240016	4-3/4 120.6	3	-	-	-	-	-	-	-
Z8240022	6-5/16 160.3	-	3	-	-	-	-	-	-
Z8208001	7-1/4 184.2	-	-	3	-	-	-	-	-
Z8208008	9 228.6	-	-	-	3	-	-	-	-
Z8208018	11-1/2 292.1	-	-	-	-	3	-	-	-
Z8208025	13-1/4 336.5	-	-	-	-	-	3	-	-
Z8208032	15 381.0	-	-	-	-	-	-	3	-
Z8208039	16-3/4 425.4	-	-	-	-	-	-	-	3

NUMBER OF PIECES PER KIT

**Table C: Two Mounting Brackets, One End Cap with Ports Left, Horizontal Configuration**

Number of Modules in Stack		1	2	3	4	5	6	7	8
Factory Assembled Stacking Kit P/N	Z669180001	Z669170002	Z669160003	Z669150004	Z669140005	Z669130006	Z669120007	Z669110008	Z669100009
	Z669110001	Z669100002	Z669090003	Z669080004	Z669070005	Z669060006	Z669050007	Z669040008	Z669030009
Unassembled Stacking Kit P/N	Z669110001	Z669100002	Z669090003	Z669080004	Z669070005	Z669060006	Z669050007	Z669040008	Z669030009
PART NUMBER	DESCRIPTION								
Z2812011	THRU-TUBE	-	2	4	6	8	10	12	14
Z2812012	LONG THRU-TUBE	2	2	2	2	2	2	2	2
Z2819006	PLUG TUBE	2	2	2	2	2	2	2	2
Z8229001	HEX NUT	3	3	6	6	6	6	6	6
Z8230001	LOCKWASHER	6	6	6	6	6	6	6	6
Z4001004	RIGHT BRACKET	1	1	1	1	1	1	1	1
Z4001002	PORTED LEFT BRACKET	1	1	1	1	1	1	1	1
TIE-RODS	(in) LENGTH (mm)								
Z8240016	4-3/4 120.6	3	-	-	-	-	-	-	-
Z8240022	6-5/16 160.3	-	3	-	-	-	-	-	-
Z8208001	7-1/4 184.2	-	-	3	-	-	-	-	-
Z8208008	9 228.6	-	-	-	3	-	-	-	-
Z8208018	11-1/2 292.1	-	-	-	-	3	-	-	-
Z8208025	13-1/4 336.5	-	-	-	-	-	3	-	-
Z8208032	15 381.0	-	-	-	-	-	-	3	-
Z8208039	16-3/4 425.4	-	-	-	-	-	-	-	3

NUMBER OF PIECES PER KIT

ZMC and ZMV Electrohydraulic Valves  
 Technical Information  
 Configuration Options

Table D: Two Mounting Brackets, Two End Caps with Ports, Horizontal Configuration

Number of Modules in Stack		1	2	3	4	5	6	7	8
Factory Assembled Stacking Kit P/N		Z669190001	Z669190002	Z669190003	Z669190004	Z669190005	Z669190006	Z669190007	Z669190008
Unassembled Stacking Kit P/N		Z669130001	Z669130002	Z669130003	Z669130004	Z669130005	Z669130006	Z669130007	Z669130008
PART NUMBER	DESCRIPTION								
Z2812011	THRU-TUBE	-	2	4	6	8	10	12	14
Z2812012	LONG THRU-TUBE	4	4	4	4	4	4	4	4
Z2819006	PLUG TUBE	-	-	-	-	-	-	-	-
Z8229001	HEX NUT	3	3	6	6	6	6	6	6
Z8230001	LOCKWASHER	6	6	6	6	6	6	6	6
Z4001001	PORTED RIGHT BRACKET	1	1	1	1	1	1	1	1
Z4001002	PORTED LEFT BRACKET	1	1	1	1	1	1	1	1
TIE-RODS	(in) LENGTH (mm)								
Z8240016	4-3/4 120.6	3	-	-	-	-	-	-	-
Z8240022	6-5/16 160.3	-	3	-	-	-	-	-	-
Z8208004	8 203.2	-	-	3	-	-	-	-	-
Z8208015	10-3/4 273.0	-	-	-	3	-	-	-	-
Z8208022	12-1/2 317.5	-	-	-	-	3	-	-	-
Z8208029	14-1/4 361.9	-	-	-	-	-	3	-	-
Z8208036	16 406.4	-	-	-	-	-	-	3	-
Z8208043	17-3/4 450.8	-	-	-	-	-	-	-	3

NUMBER OF PIECES PER KIT

ZMC and ZMV Electrohydraulic Valves  
 Technical Information  
 Configuration Options

Table F: One Tapped End Plate, One End Cap with Ports, Vertical Configuration

Number of Modules in Stack		1	2	3	4	5	6	7	8
Factory Assembled Stacking Kit P/N		Z669210001	Z669210002	Z669210003	Z669210004	Z669210005	Z669210006	Z669210007	Z669210008
Unassembled Stacking Kit P/N		Z669150001	Z669150002	Z669150003	Z669150004	Z669150005	Z669150006	Z669150007	Z669150008
PART NUMBER	DESCRIPTION								
Z2812011	THRU-TUBE	2	4	6	8	10	12	14	16
Z2812012	LONG THRU-TUBE	-	-	-	-	-	-	-	-
Z2819006	PLUG TUBE	2	2	2	2	2	2	2	2
Z8229001	HEX NUT	-	-	3	3	3	3	3	3
Z8230001	LOCKWASHER	3	3	3	3	3	3	3	3
Z4001007	END PLATE	-	-	-	-	-	-	-	-
Z4001006	TAPPED END PLATE	1	1	1	1	1	1	1	1
TIE-RODS	(in) LENGTH (mm)								
Z8240015	4-1/2 114.3	3	-	-	-	-	-	-	-
Z8240022	6-5/16 160.3	-	3	-	-	-	-	-	-
Z8208004	8 203.2	-	-	3	-	-	-	-	-
Z8208011	9-3/4 247.6	-	-	-	3	-	-	-	-
Z8208018	11-1/2 292.1	-	-	-	-	3	-	-	-
Z8208025	13-1/4 336.5	-	-	-	-	-	3	-	-
Z8208032	15 381.0	-	-	-	-	-	-	3	-
Z8208039	16-3/4 425.4	-	-	-	-	-	-	-	3

NUMBER OF PIECES PER KIT

Table E: Two End Plates, One Tapped, Vertical Configuration

Number of Modules in Stack		1	2	3	4	5	6	7	8
Factory Assembled Stacking Kit P/N		Z669200001	Z669200002	Z669200003	Z669200004	Z669200005	Z669200006	Z669200007	Z669200008
Unassembled Stacking Kit P/N		Z669140001	Z669140002	Z669140003	Z669140004	Z669140005	Z669140006	Z669140007	Z669140008
PART NUMBER	DESCRIPTION								
Z2812011	THRU-TUBE	-	2	4	6	8	10	12	14
Z2812012	LONG THRU-TUBE	-	-	-	-	-	-	-	-
Z2819006	PLUG TUBE	4	4	4	4	4	4	4	4
Z8229001	HEX NUT	-	-	3	3	3	3	3	3
Z8230001	LOCKWASHER	3	3	3	3	3	3	3	3
Z4001007	END PLATE	1	1	1	1	1	1	1	1
Z4001006	TAPPED END PLATE	1	1	1	1	1	1	1	1
TIE-RODS	(in) LENGTH (mm)								
Z8240009	3 76.2	3	-	-	-	-	-	-	-
Z8240016	4-3/4 120.6	-	3	-	-	-	-	-	-
Z8208001	7-1/4 184.2	-	-	3	-	-	-	-	-
Z8208008	9 228.6	-	-	-	3	-	-	-	-
Z8208015	10-3/4 273.0	-	-	-	-	3	-	-	-
Z8208022	12-1/2 317.5	-	-	-	-	-	3	-	-
Z8208029	14-1/4 361.9	-	-	-	-	-	-	3	-
Z8208036	16 406.4	-	-	-	-	-	-	-	3

NUMBER OF PIECES PER KIT

Module Identification

Each valve module includes a nameplate affixed to the housing. This information includes:

**Model Number:** This defines the specific unit.

**Serial Number:** This is used to identify the manufacturing location, build date, and the sequence in the build.



ZMC and ZMV Electrohydraulic Valves  
 Technical Information  
 Outline Drawings

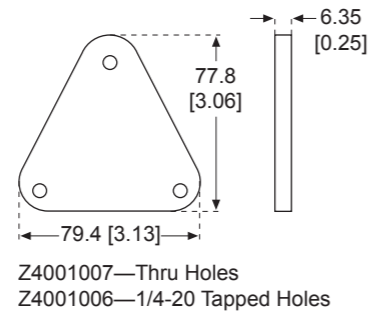

END PLATES

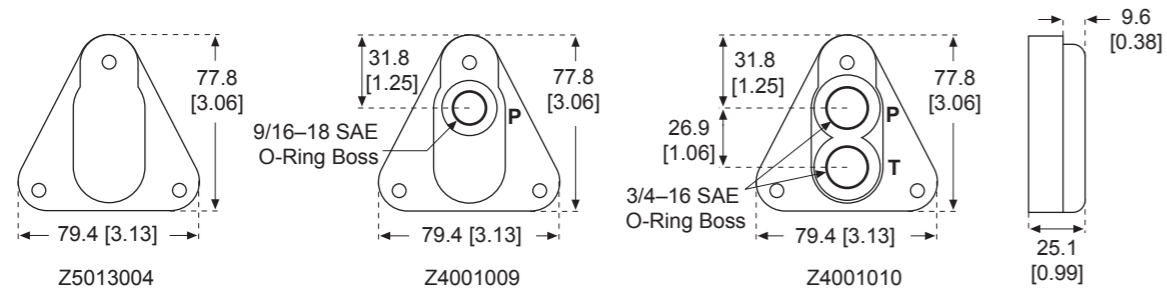

END CAPS

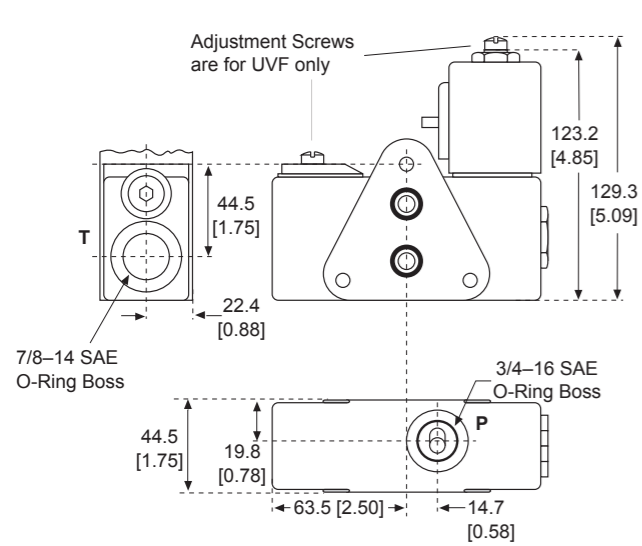

ZMC-UVO, ZMC-UVC, ZMC-UVF

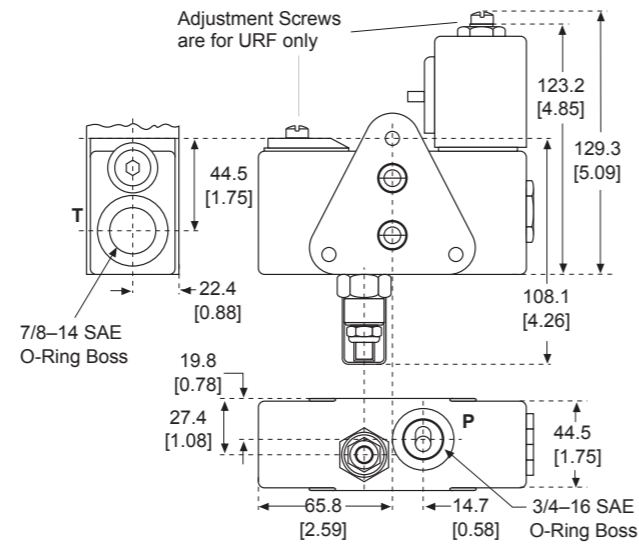

ZMC-URO, ZMC-URF

ZMC and ZMV Electrohydraulic Valves  
 Technical Information  
 Outline Drawings

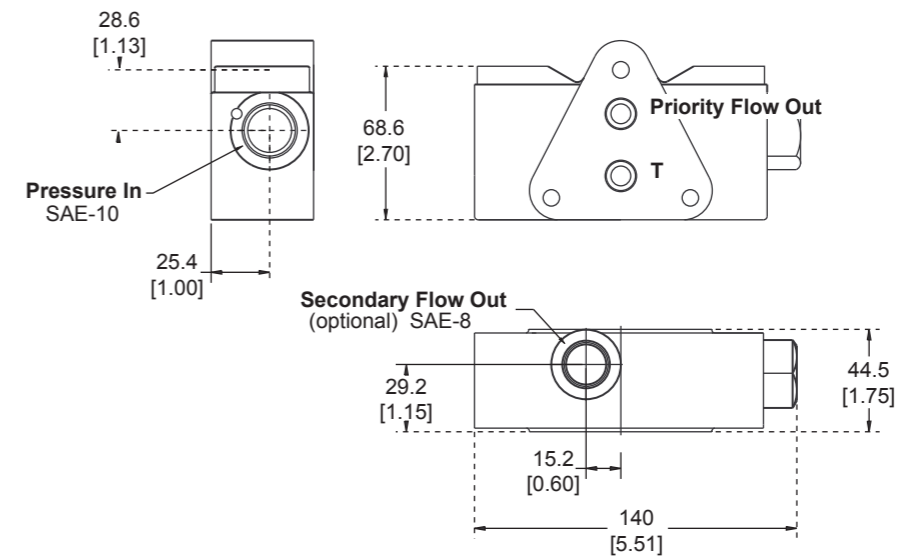

ZMC-PFD

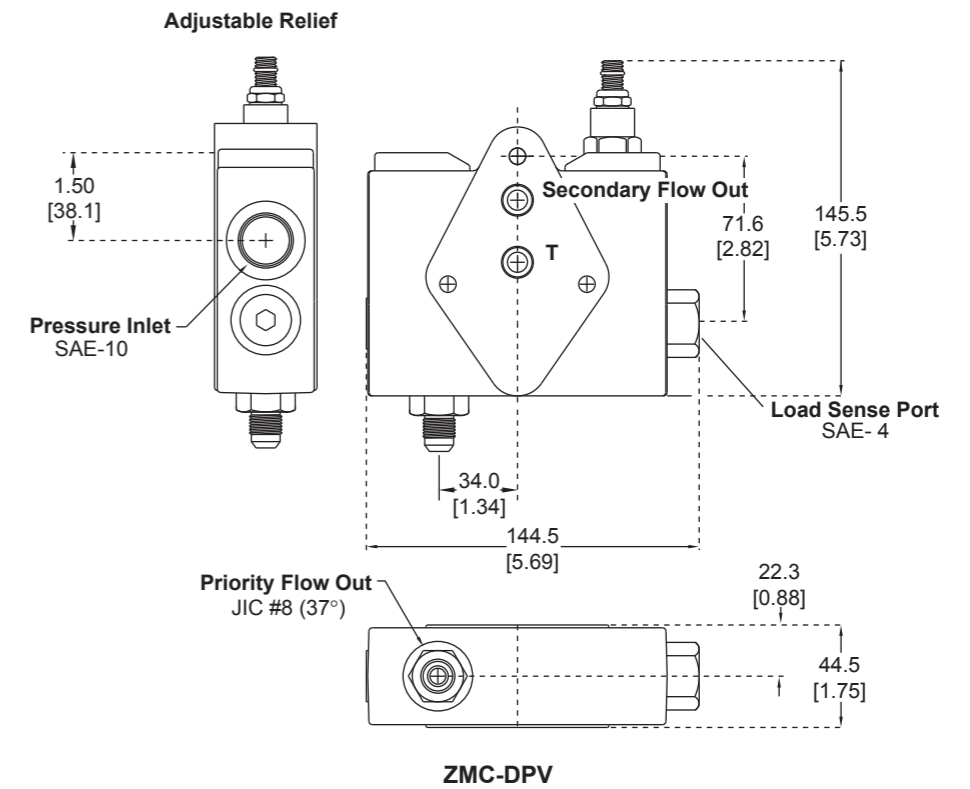

ZMC-DPV

ZMC and ZMV Electrohydraulic Valves  
 Technical Information  
 Outline Drawings

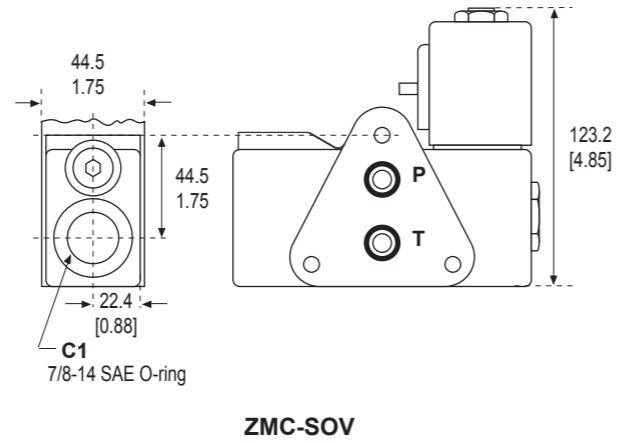
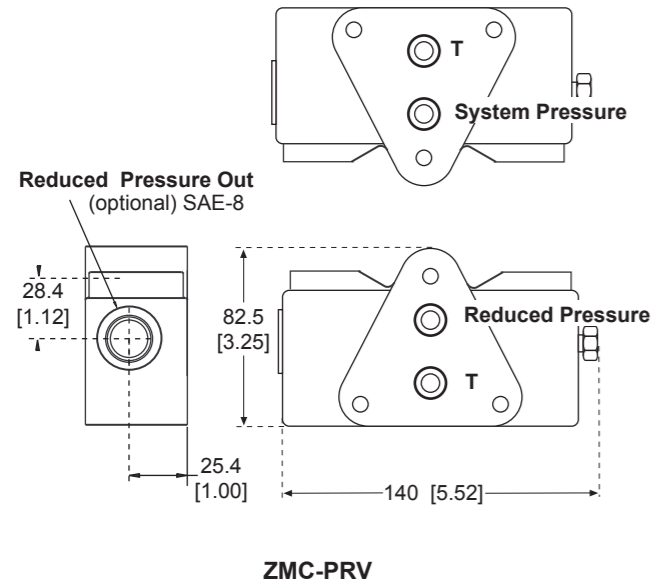

ZMC and ZMV Electrohydraulic Valves  
 Technical Information  
 Outline Drawings

