



Application Note



DSS-2 Two-Channel Digital Speed Switch

Installation Guide

Application Note 36599A



WARNING

Read this entire manual and all other publications pertaining to the work to be performed before installing, operating, or servicing this equipment. Practice all plant and safety instructions and precautions. Failure to follow instructions can cause personal injury and/or property damage.

The engine, turbine, or other type of prime mover should be equipped with an overspeed shutdown device to protect against runaway or damage to the prime mover with possible personal injury, loss of life, or property damage.

The overspeed shutdown device must be totally independent of the prime mover control system. An overtemperature or overpressure shutdown device may also be needed for safety, as appropriate.



CAUTION

To prevent damage to a control system that uses an alternator or battery-charging device, make sure the charging device is turned off before disconnecting the battery from the system.

In systems where large inductive loads are switched on the DC power buss, surge impulse energy will be present due to the switching. To address surge energy affects on the control, appropriate suppression devices must be installed in the DC power buss prior to the control's power connection.

Electronic controls contain static-sensitive parts. Observe the following precautions to prevent damage to these parts.

- Discharge body static before handling the control (with power to the control turned off, contact a grounded surface and maintain contact while handling the control).
- Avoid all plastic, vinyl, and Styrofoam (except antistatic versions) around printed circuit boards.
- Do not touch the components or conductors on a printed circuit board with your hands or with conductive devices.



IMPORTANT DEFINITIONS

WARNING—indicates a potentially hazardous situation which, if not avoided, could result in death or serious injury.



CAUTION—indicates a potentially hazardous situation which, if not avoided, could result in damage to equipment.



NOTE—provides other helpful information that does not fall under the warning or caution categories.

Revisions—Text changes are indicated by a black line alongside the text.

QCC, LLC reserves the right to update any portion of this publication at any time. Information provided by QCC is believed to be correct and reliable. However, no responsibility is assumed by QCC, LLC unless otherwise expressly undertaken.

All Rights Reserved

Regulatory Compliance

European Compliance for CE Marking

EMC Directive

Declared to 89/336/EEC COUNCIL DIRECTIVE of 03 May 1989 on the approximation of the laws of the Member States relating to electromagnetic compatibility.

Electromagnetic Compatibility

Testing was performed to ISO/EN 14982:1998 and EN 13309:2000 standards.

Evaluations, other than specific testing, were performed to cover:

- EN 12895:2000
- EN 61000-6-2:2001
- EN 61000-6-4:2001

Testing to EN 14982:1998 and application specific installation requirements cover evaluations. (See Chapter 1 of this manual for intended usage of this unit.)

EMC Limitations

All cabling for these controllers is limited to less than 3m (9.84').

Power cabling is limited to less than 10m (32.8') in total length.

See wiring diagrams for specific cable types required.

Electrostatic Discharge Awareness

All electronic equipment is static-sensitive, some components more than others. To protect these components from static damage, you must take special precautions to minimize or eliminate electrostatic discharges.

Follow these precautions when working with or near the control.

1. Before doing maintenance on the electronic control, discharge the static electricity on your body to ground by touching and holding a grounded metal object (pipes, cabinets, equipment, etc.).
2. Avoid the build-up of static electricity on your body by not wearing clothing made of synthetic materials. Wear cotton or cotton-blend materials as much as possible because these do not store static electric charges as much as synthetics.
3. Keep plastic, vinyl, and Styrofoam materials (such as plastic or Styrofoam cups, cup holders, cigarette packages, cellophane wrappers, vinyl books or folders, plastic bottles, and plastic ash trays) away from the control, the modules, and the work area as much as possible.
4. Do not remove the printed circuit board (PCB) from the control cabinet unless absolutely necessary. If you must remove the PCB from the control cabinet, follow these precautions:
 - Do not touch any part of the PCB except the edges.
 - Do not touch the electrical conductors, the connectors, or the components with conductive devices or with your hands.
 - When replacing a PCB, keep the new PCB in the plastic antistatic protective bag it comes in until you are ready to install it. Immediately after removing the old PCB from the control cabinet, place it in the antistatic protective bag.



CAUTION

To prevent damage to electronic components caused by improper handling, read and observe the precautions in QCC manual 82715, *Guide for Handling and Protection of Electronic Controls, Printed Circuit Boards, and Modules*.

Chapter 1.

General Information

The DSS-2 is a two-channel electronic speed switch designed for use on engine applications where it can perform a variety of speed related functions such as starter motor disable and engine overspeed protection. The DSS-2 monitors engine rpm via a magnetic pickup (MPU) input and controls two independent relays. Once engine speed exceeds the user-selected speed setpoint, the relay will go to the designated set condition. DSS-2 has two multi-turn potentiometers for speed setpoint adjustment. A serial interface is provided for additional adjustments with the All-purpose Calibration Tool (ACT).

DSS-2 can be re-configured with the ACT to act as a glow plug controller or engine autocrank controller.

Intended Usage

The DSS-2 is intended as a sub-system for integration into construction/commercial and industrial engine systems by original equipment manufacturers and industrial plants. It is not intended for consumer or on-highway vehicles or for use by the general consumer/public. Typical applications include generator sets, compressors, construction machinery and farm vehicles.

Specifications

QCC P/N: 8800-1001

Electrical

Power Input	9-30 Vdc, Reverse polarity protected
Electromagnetic Compatibility	See Regulatory Compliance on page i.
Operating Current: Both Channels On: Both Channels Off:	12 V: 100 mA / 24 V: 100 mA 12 V: 50 mA / 24 V: 50 mA
Relay Contact Ratings @ 28 Vdc	Resistive Load: 1 to 10A Inductive Load: 1 to 8A

Mechanical

Operating Temperature	-40°F to +185°F (-40°C to 85°C)
Vibration	4 G's from 40 to 2000 Hz
Shock	10 G's @ 45 Hz
Housing	UV, chemical resistant. UL 94 V-O flame retardant. Encapsulated for reliability in harsh environments
Terminations	Euro-style terminal block
Calibration	Manual or with PC-based All-purpose Calibration Tool / ACT [SA-5206]
Weight:	0.38 lbs (0.17 kg)

Chapter 2. Installation



CAUTION

Take adequate protection to ensure personal and equipment safety and follow the suggested installation sequence given below.

Refer to **Figures 1 & 2** to install the system and subcomponents.

Mounting

Mount the unit in a location where the effects of vibration and temperature are within the specified range. Operating temperature: -40°F to +185°F (-40°C to +85°C); vibration: 6 G's from 40 to 2000 Hz. (See **Figure 1** for controller dimensions.)

Dimensions in inches. Dimensions in () are in millimeters.

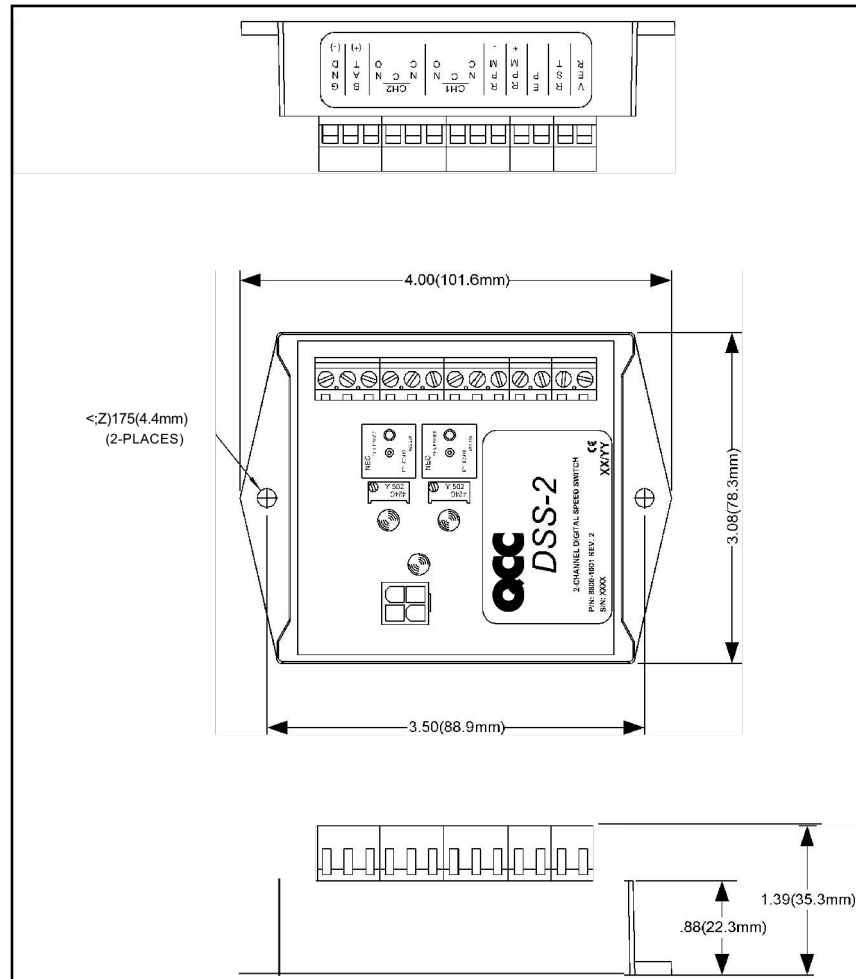

Figure 1. DSS-2 Dimensions

Wiring

DSS-2 has thirteen Euro-style screw terminals for:

- *Battery Positive and Negative* (9-30 Vdc). Reverse voltage protected
- *Two form-C relays* (10A continuous). Independent Common (C), Normally Closed (NC) and Normally Open (NO) contacts are provided. DSS-2 is factory programmed for standard relay logic (relay de-energized below set speed), but may be modified with the ACT for reverse relay logic (relay energized below set speed). External diodes should be added for transient suppression with inductive loads.
- *Magnetic Pickup (MPU) Positive and Negative* (2 Vac minimum at 1000 Hz). The controller is factory programmed for 2500 to 5000 Hz. This range may be modified with the All-purpose Calibration Tool (ACT) to cover 10-10,000 Hz or operate in units of rpm.
- *Reset Switch Input (RST)*: A switch to battery positive switch input is provided for manual reset functions. DSS-2 is factory programmed for automatic reset at 80% of set speed, but may be modified with the ACT for manual or latched reset.
- *Engine Protection Switch Input (EP)*: A switch to battery positive switch input is provided for connection to external engine protection devices.
- *Verify Switch Input (VER)*: A switch to battery positive switch input is provided for a verify function. Activating this switch will reduce both channel set frequencies to 70% of their normal values.

Use insulated, automotive grade wiring (minimum 18 AWG or 1 mm²) for all connections. Shielded wiring is recommended for the MPU.

To use the external connections:

1. Loosen the terminals with a small blade screwdriver.
2. Strip wire.
3. Insert wire into terminal hole.
4. Tighten terminal with a small blade screwdriver.

Refer to **Figure 2**. Use proper wire gauges (18 AWG/ 1 mm² minimum). All wire insulation should be appropriate for engine applications. Terminations must be impervious to moisture to prevent shorts and corrosion.

Use of convoluted tubing, conduit, or other wire shielding is recommended to minimize the likelihood of mechanical damage to wires. Avoid routing wires near sharp edges or near locations that can cause the wires to be pinched or damaged.

Controller Pinout

Use the diagram below to connect your DSS-2 controller to battery power, the mag pickup, loads, switches and ACT.



NOTE

All cabling for the DSS-2 controller is limited to less than 3m (9.84'). Power cabling is limited to less than 10m (32.8') in total length. The wiring diagram below shows specific cable types required.

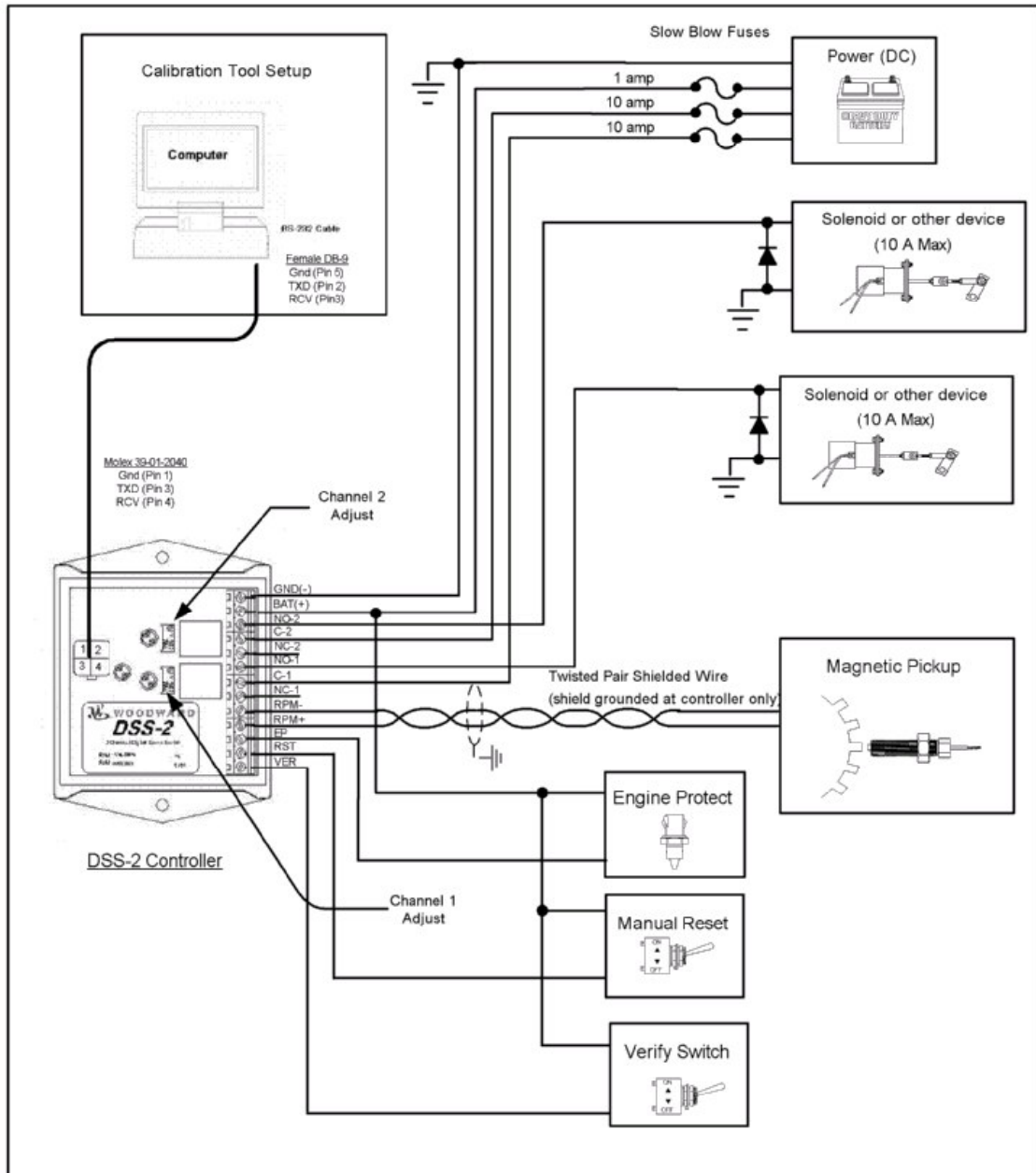

Figure 2. DSS-2 Wiring Diagram



CAUTION

To prevent damage to the controller, make sure that it is wired in accordance with the wiring instructions and diagrams in this manual.

Chapter 3. Calibration

Manual Calibration

Calibration is best done with a frequency generator to simulate the engine speed input and a frequency meter. A zero-crossing input of 2 Vac minimum is required. Setup consists of the following:

1. Set potentiometers to maximum frequency (fully clockwise – potentiometer will click at end of travel).
2. Apply power to controller. All three LEDs should turn on for one second, indicating normal operation.
3. Turn on frequency generator and set to desired frequency. The green status LED should turn on continuously, indicating a good speed signal from the generator.
4. Adjust speed setpoints until desired set speeds are achieved. Red LEDs should illuminate when set speeds are reached.
5. Install DSS-2 on engine and confirm MPU input with engine running. Confirm speed switch operation. If concerned about overspeeding the engine or load, attach 12 volts to the verify (VER) input. Speed switching will occur at 70% of the actual set speed.

ACT Calibration

With the addition of the All-purpose Calibration Tool (ACT) computer interface (QCC P/N: SA-5206), the user can adjust the following features:

- Frequency range for each channel (factory set to 2500–5000 Hz.)
- Standard or reverse relay logic (factory set to standard relay logic)
- Reset mode: Auto, Manual or Latched (factory set to auto)
- Engine protection set (factory set to go to set mode on engine protection switch input)
- Autocrank controller – can reassign output channel to work as an engine autocrank controller
- Glow plug control – can reassign output channel to work as a glow plug controller



CAUTION

The serial/COM port and ACT software are intended only for configuration and periodic service. Do not leave a computer and/or serial/COM cable connected to the serial/COM port.

Chapter 4. Diagnostics

The DSS-2 is equipped with three LEDs: one green and two red.

The green status LED on the DSS-2 can be used for diagnosing a variety of problems:

- When the DSS-2 is powered up, all three LEDs will turn on for one second then turn off. If they do not, the DSS-2 is either not receiving power or it is completely non-functional.
- If a fault condition exists, the green status LED will flash a code that indicates the nature of the fault. Refer to the table below. The ACT can also be used to look up current and historic faults.
- If there are no faults, the green status LED will turn on continuously when the DSS-2 receives a valid signal from the magnetic pickup. If it does not, then there is not a valid signal.

The red channel LEDs indicate the condition of the assigned channel:

- When the channel is in the Set condition (regardless of Forward or Reverse configuration), the LED will be on.
- When the channel is in the Reset condition (regardless of Forward or Reverse configuration), the LED will be off.

Table 2. Fault Codes

FLASH CODE	FAULT	RESPONSE	CAUSE
1	Channel 1 Overspeed	Set Condition	Engine rpm has exceeded Channel 1 speed setpoint and CHNL_1_CONFIG.7 = 1.
2	Channel 2 Overspeed	Set Condition	Engine rpm has exceeded Channel 2 speed setpoint and CHNL_2CONFIG.7 = 1.
4	Engine Protection	Set Condition	Engine Protection switch activated.
7	Loss of Speed Signal	Set Condition	Disappearance of speed signal. . . No speed signal within LOSS_TIME of power up OR No speed signal within AUTOCRANK_NS_TIME of autocrank.
8	Overcrank	No autocrank	There have been AUTOCRANK_MAX_TRIES attempts to start engine, and engine has not started.
9	DSS-2 Uncalibrated	No operation	Parameter PULSES_PER_REV must have a non-zero value. Enter the number of teeth per engine rev if you wish to work in units of RPM, or enter a value of 60 if you wish to work in units of Hz.
10	Channel 1 Set Pot out-of-range	Defaults to minimum speed	Consult factory.
11	Channel 2 Set Pot out-of-range	Defaults to minimum speed	Consult factory.
16	Controller failed	Yes	Consult factory.

**We appreciate your comments about the content of our publications. Send
comments to: weborder@qccorp.com
Please include the manual number from the front cover of this publication.**



7301 W. Wilson Avenue
Harwood Heights, IL 60706

Phone +1 708-887-5400

Website—www.qccorp.com